



INNOVATECH PRODUCTS & EQUIPMENT. 4701 Allmond Ave, Louisville, KY 40209, USA
Telephone: 1-425-405-9100

RIDE-ON TERMINATORS

T-3000XME

COMPLETE MANUAL

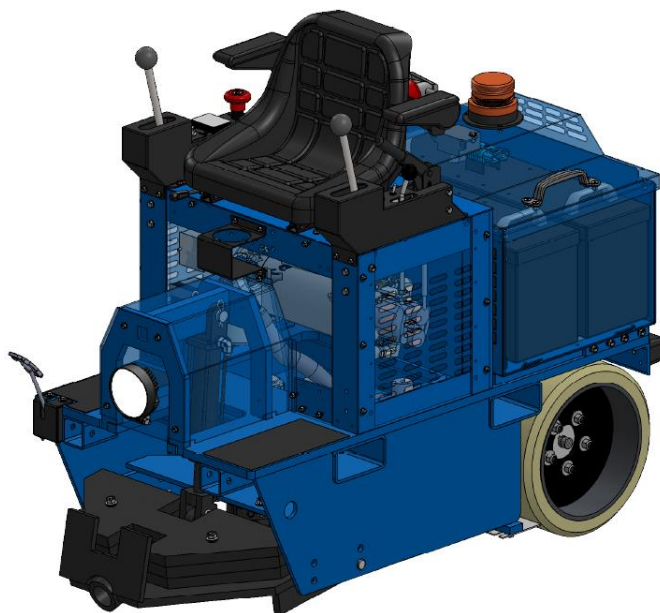

www.BARTELLGLOBAL.com



www.BARTELLGLOBAL.com

Bartell Morrison Inc.
 375 Annagem Boulevard
 Mississauga, Ontario, Canada
 L5T 3A7
 Tel: (647) 953-4100
 Fax: (647) 953-4101

Bartell Morrison USA LLC
 200 Commerce Drive, Unit A
 Freehold, NJ, USA
 07728
 Tel: (848) 225-8100
 Fax: (848) 225-8101

SPE International Ltd
 Honeyholes Lane
 Dunholme, Lincoln, England
 LN2 3SU
 Tel: 01673 860709
 Fax: 01673 861119

Innovatech
 4701 Allmond Ave
 Louisville, Kentucky, USA
 40209
 Tel: (425) 405-9100
 Fax: (425) 405-9101

ORIGINAL LANGUAGE OPERATING MANUAL FOR
 BARTELL RIDE-ON TERMINATORS

© 2017 Bartell Morrison Inc.

No part of this work may be reproduced or transmitted in any form or by any means, electronic or mechanical, including photocopying and recording, or by any information storage or retrieval system without the prior written permission of Bartell Morrison Inc. unless such copying is permitted by federal copyright laws.

Address inquiries or reference permissions care of: Bartell Morrison Inc., 375 Annagem Blvd., Mississauga, Ontario, Canada L5T 3A7

REV.	DATE	DESCRIPTION	APPROVED BY:
-	07/14/17	Initial release	
1	02/13/18	Corrected part numbers/quantities, renumbered balloons	

SAFETY PRECAUTIONS



DANGER EXPLOSION HAZARD

Never operate the machine in an explosive atmosphere, near combustible materials, or where ventilation does not clear exhaust fumes.



WARNING BURN HAZARD

Never come into contact with the engine or muffler when engine is operating or shortly after it is turned off. Serious burns may occur.



WARNING ROTATING HAZARD

Never place hands or feet inside safety guard rings. Serious injury will result from contact with rotating blades.



CAUTION MOVING PARTS

Before starting the machine, ensure that all guards and safety devices are in place and functioning properly.



ATTENTION READ OWNER'S MANUAL

Read and understand owner's manual before using this machine. Failure to follow operating instructions could result in serious injury or death.

TABLE OF CONTENTS

1.	<u>INTRODUCTION</u>	6
2.	<u>ABOUT THIS MANUAL</u>	6
3.	<u>IMPORTANT SAFETY INSTRUCTIONS</u>	7
○	1. SAFETY INSTRUCTIONS FOR ALL TOOLS	7
○	2. ADDITIONAL SAFETY RULES FOR RIDING FLOOR SCRAPERS	8
4.	<u>GENERAL OPERATING INSTRUCTIONS FOR THE TERMINATOR®</u>	9
5.	<u>SAFETY FEATURES</u>	9
○	1. AUTO STOP	9
○	2. EMERGENCY STOP BUTTON	9
○	3. SAFETY INSTRUCTIONS	10
6.	<u>TERMINATOR® INFINITY SPECIFICATIONS</u>	10
○	1. TOOLS AND SUPPLIES	10
7.	<u>VENTILATION REQUIREMENTS</u>	10
8.	<u>GUARDS, WARNING NOTICES & SIGNS</u>	10
9.	<u>SERVICE INSTRUCTIONS & PERSONNEL</u>	11
10.	<u>REPLACEMENT PARTS & MATERIALS</u>	11
11.	<u>UNCRATING AND PREPARING THE TERMINATOR® FOR OPERATION</u>	11
○	1. TO REMOVE THE TERMINATOR® FROM CRATE WITH A FORKLIFT:	12
○	2. TO REMOVE THE TERMINATOR® FROM CRATE WITHOUT A FORKLIFT:	12
12.	<u>LOADING/UNLOADING PROCEDURES</u>	12
13.	<u>OPERATOR CONTROLS</u>	12
○	1. DRIVE AND BLADE CONTROLS	12
○	2. AUTO STOP	13
○	3. EMERGENCY BRAKE	13
14.	<u>DISPLAY & INDICATORS</u>	13
○	1. BATTERY/HOUR METER	13
○	2. EMERGENCY STOP	ERROR! BOOKMARK NOT DEFINED.
15.	<u>ELECTRIC MOTOR & BATTERIES</u>	13
16.	<u>BLADE ASSEMBLY</u>	14
17.	<u>TAKING UP FLOOR COVERINGS</u>	14
18.	<u>TRICYCLE OR CASTER WHEELBASE AND TIRES</u>	14
19.	<u>BATTERY SAFETY</u>	15
○	1. RECEIVING THE TERMINATOR®	15

○	2. LIFTING BATTERIES	15
○	3. WEAR PROTECTIVE CLOTHING	16
○	4. IC1200 SAFETY	ERROR! BOOKMARK NOT DEFINED.
20.	<u>SETTING UP A CHARGING AREA</u>	16
○	1. CONNECTING/DISCONNECTING CHARGER	16
○	2. BASIC CHARGING FACTS	17
21.	<u>IC1200 CHARGER INFO</u>	ERROR! BOOKMARK NOT DEFINED.
○	1. LEFT DISPLAY	ERROR! BOOKMARK NOT DEFINED.
○	2. RIGHT DISPLAY	ERROR! BOOKMARK NOT DEFINED.
22.	<u>MAINTENANCE PROCEDURES</u>	17
23.	<u>PARTS LIST</u>	18
24.	<u>WARRANTY</u>	44

1. Introduction

The Terminator[®] Carpet and Tile Removal Machine is intended for use on large demolition and asbestos abatement projects as well as smaller floor covering removal jobs. Designed and built by experienced floor covering demolition and installation experts, the machine incorporates several design features that are essential for efficient operation:

- Tricycle wheelbase and short turning radius allows for better turning ability - especially in narrow spaces.
- Jaw position adjustments allow for changing the angle of the blade for any application.
- Ballast in front and rear provides extra traction needed for tile and glue removal.
- Foot control for a very smooth start and stop.
- Built-in forklift transport slots allow for easy loading and unloading at job sites.

If operated and cared for as instructed in this Manual, the Terminator[®] provides trouble-free, safe, and efficient performance.

2. About This Manual

This Manual contains the information and procedures to assist you to operate and maintain the Terminator[®] machine safely and correctly. Read this Manual before you operate or service the equipment. If you need additional information or assistance, please get in touch with our Customer Service Department:

Innovatech Products & Equipment Co.
4701 Allmond Ave
Louisville, KY 40209
(425) 402-1881 or 800-267-6682
Fax (425) 402-8547
Email: service@InnovatechProducts.com

NOTE: Throughout this Manual directional instructions (left, right, up, down, push, pull, etc.) are given from the point of view of the operator performing the action.

3. Important Safety Instructions



WARNING: *When using electric tools, basic safety precautions should always be followed to reduce the risk of fire, electric shock, and personal injury, including the following: **READ ALL INSTRUCTIONS***

1. Safety Instructions for All Tools

- **KEEP GUARDS IN PLACE** and in working order.
- **REMOVE ADJUSTING TOOLS AND WRENCHES.** Form habit of checking to see that keys and adjusting wrenches are removed from the Terminator® before turning tool on.
- **KEEP WORK AREA CLEAN.** Cluttered areas invite accidents.
- **KEEP CHILDREN AWAY.** All visitors should be kept a safe distance from the work area.
- **WEAR PROPPER APPAREL.** No loose clothing, gloves, neckties, rings, bracelets or other jewelry to get caught in moving parts. Non-slip footwear is recommended. Wear protective hair covering to contain long hair.
- **ALWAYS WEAR SAFETY GLASSES.** Also use a face or dust mask if operating in a dusty environment. All users and bystanders must wear eye protection that conforms to ANSI Z87.1. (CAN/CSA Z94.3)
- **MAINTAIN EQUIPMENT WITH CARE.** Keep equipment clean for best and safest performance. Follow instructions for lubrication and changing accessories.
- **DISCONNECT BATTERY** before servicing.
- **REDUCE THE RISK OF UNINTENTIONAL STARTING.** Make sure handles are centered.
- **USE RECOMMENDED ACCESSORIES.** Consult the instruction manual for recommended accessories.
- **NEVER STAND ON TOOL.** Serious injury could occur if the machine is tipped or rocked.
- **CHECK DAMAGED PARTS.** Before further use of the tool, a guard or other part that is damaged should be carefully checked to determine that it will operate properly and perform its intended function Check for alignment of moving parts, binding of moving parts, breakage of parts, mounting and any other conditions that may affect its operation. A guard or other part that is damaged should be properly repaired or replaced. Do not use tool if switch does not turn it on and off.
- **NEVER LEAVE EQUIPMENT RUNNING UNATTENDED. TURN POWER OFF.** Don't leave equipment until it comes to a complete stop.
- **DO NOT OPERATE ELECTRIC TOOLS NEAR FLAMABLE LIQUIDS OR GASSES OR EXPLOSIVE ATMOSPHERES.** Motors in these tools may spark and ignite fumes.

2. Additional Safety Rules for Riding Floor Scrapers



CAUTION: FAILURE TO HEED THESE WARNINGS MAY RESULT IN SERIOUS PERSONAL INJURY OR DEATH AND SERIOUS DAMAGE TO THE TERMINATOR®.

The Terminator® is to be operated only by qualified, trained personnel.

DON'T attempt to operate the Terminator® if you are not thoroughly familiar with the operation of the Terminator®.

DON'T operate the Terminator® unless every guard, warning notice or sign is in place.

DON'T use the Terminator® on roofs or floors not designed to carry the weight of the machine.

DON'T attempt to operate on anything but the designated voltage.

DON'T wedge anything against the motor fan to hold motor shaft.

DON'T operate equipment without guards in place.

DON'T operate the Terminator® near an open flame or smoking materials

DON'T stand directly behind or in front of the Terminator® when power is enabled.

DON'T lift the hood, inspect the blade, or otherwise service or maintain the Terminator® while power is enabled.

DON'T operate the Terminator® if the top cover is open.

DON'T overreach. Keep proper footing and balance at all times.

DON'T run the machine into piles of debris, as this may cause the machine to become unstable and tip over.

DON'T sit on or stand next to, under or around the Terminator® when it is being transported in a moving vehicle, whether by itself or with other equipment.

DON'T attempt to use the Terminator® on a non-horizontal surface or turn the Terminator® around on a ramp or hill.

DON'T put your hands or feet in the blade area when the Terminator® is running.

DO turn the power off when not in use.

DO use personal safety equipment such as steel toe shoes, safety glasses, gloves, and ear plugs.

DO use gloves when changing blades and removal tools. Tools may be hot and cause burns.

DO familiarize yourself with all safety features and controls before each use.

DO use the Terminator® only for the purpose for which it was designed. Attempting to alter the Terminator® will invalidate applicable warranties and possibly damage the machine.

DO reduce speed next to walls, machinery and other objects.

DO pre-survey the floor for cracks, ditches, trenches, electrical outlets or bolts, which could catch the blade of the machine.

DO operate the Terminator® at a safe speed.

4. General Operating Instructions for the Terminator®

The Terminator® is designed to remove carpet, tile and glue residue from floors.

- When removing product, position removed product so it rolls to the side of the machine or have someone on the side of the machine remove the product. NEVER WALK IN FRONT OF OR BEHIND THE TERMINATOR® WHILE IT IS RUNNING.
- Sharpen blades or dice material into narrower widths if machine slows down or seems to be struggling.
- Do not use the Terminator® within one foot of walls or stationary objects. Damage to objects may occur if the Terminator® strikes them.
- Use safe, OSHA-approved tools and methods for sharpening blades.
- Make sure the Terminator® has a charged fire extinguisher, working backup alarm, and strobe light before operating.

5. Safety Features

The Terminator® is equipped with several features to help ensure your safety and the safety of workers around you.

1. Auto Stop

The Terminator® has two drive levers located to the right and left of the operator seat and a jaw height lever to the left of the operator seat. The drive levers control the forward, reverse, left, and right directions of the machine; the jaw height lever raises and lowers the jaw assembly. You must push (forward) or pull (reverse) and hold the levers in position to drive the machine or move the jaw assembly in the direction desired. When you release a lever, the Terminator® or jaw automatically STOPS and will not move again until you push/pull and hold the levers again. However, these levers are not meant as brakes. Block wheels with a floor block when stopping on a ramp and use the emergency brake. Without the emergency brake the machine may roll forward or backwards on any sloping surface.

2. Warning Light and Back-Up Alarm

An amber light is installed on the top section of the rear battery box. When the ignition is in the ON position, the warning light will flash. When the drive control is set in REVERSE, the back-up alarm will sound.

3. Fire Extinguisher

A fire extinguisher with gauge is installed on the hood behind the operator's seat within the operator's reach. As a safety measure, regularly inspect the gauge and recharge the fire extinguisher as needed to maintain full capacity. Always recharge the extinguisher after each use.

4. Emergency Stop Button

To the right side of the operator seat is a red emergency stop button. This will remove power from the motor and other electronic components. **Warning!** Removing power from the Terminator® while on a hill or ramp can lead to a dangerous rollaway situation. Always engage the parking brake before disconnecting power.

5. Safety Instructions

The Terminator® is designed for safe operation by trained, designated personnel. To help ensure your safety as a designated operator, read these safety instructions before you operate the equipment. Regardless of your experience with machinery, the Terminator® has unique features and systems which you need to know about and understand before you operate or service the machine.

6. Terminator® T-3000XME Specifications

Element	English	Metric
Length	55"	1398 mm
Width	27.75"	705 mm
Height	47"	1194 mm
Weight	1875 lbs.	852 kg
Tires (OD & W)	15" x 8"	381 mm x 203 mm
Motor Voltage	48 VDC	
Motor Power	10 HP	7.5 kW
Batteries	12 VDC 115 Ah (24 VDC 115Ah per pack)	
Motor Operating Speed	0-3600 RPM	
Hydraulic Oil Type	ISO 46	
Hydraulic Oil Capacity	11 Gal	41.6 L
Hydraulic Relief Valve Pressure	2200 psi	15.17 MPa

1. Tools and Supplies

Maintenance tools and supplies are not provided with the machine. The following are suggested items to have on the job site.

1. 4" or 7" Grinder
2. 10"-15" Crescent Wrench
3. 16-20 oz. Hammer
4. 3/8" or 1/2" Socket Set
5. Grease Gun
6. WD 40
7. 3/4" Open End and Box Wrench
8. Screw Driver Set
9. Safety Glasses
10. Ear Plugs

7. Ventilation Requirements

Charge the batteries only in well-ventilated areas. (See Battery Safety section)

8. Guards, Warning Notices & Signs

The guards, warning notices and signs are placed on the Terminator® for your protection. If one of them becomes damaged or is lost, contact our Customer Service Department to order a replacement.

9. Service Instructions & Personnel

Like other machinery, the Terminator® requires regular inspection and maintenance of the batteries, motor, hydraulic system and other parts. To prolong the safe and efficient operating life of the machine, clean and service it as instructed in the Maintenance section of this manual.

Always use trained personnel to service the equipment. **Never** allow anyone to service the equipment that has not been specifically trained to do so.

If you need help with a service or maintenance problem, contact our Customer Service Department.

10. Replacement Parts & Materials

The Terminator® is designed and engineered to operate safely and efficiently with the parts and materials installed on it in our factory. To ensure the continued safe and efficient operation of the equipment, use replacement parts and materials that meet both of the following requirements:

- Innovatech must solely authorize replacement parts and materials.
- Replacement parts and materials must be identical to the items originally provided with the machine, except as authorized by Innovatech.

Never use “equivalent” or substitute parts, except as expressly authorized by Innovatech.

If you fail to adhere to these instructions, you may cause injury to yourself and/or others, cause damage to the Terminator®, and invalidate applicable warranties.

If you are in doubt about any replacement parts or materials, call our Customer Service Department for assistance.

11. Uncrating and Preparing the Terminator® for Operation

When you receive the Terminator®, inspect the outside of the crate completely, to detect damage to the crate itself. If it is damaged, notify the carrier immediately and follow his/her instructions to file a claim.

Carefully uncrate the machine and inspect it for damage that may have occurred during shipping. If the shipment is damaged, notify the carrier immediately and file a claim in the normal manner.

Check packing slip for complete shipment. If shipment is incomplete, notify our Customer Service Department within 24 hours.

Remove the crate debris, set aside the blades and other packages, and prepare the Terminator® for operation:

1. To remove the Terminator® from a crate with a forklift:

1. Forklift slots have been provided on the sides of the Terminator® for moving the terminator with a forklift.

2. To remove the Terminator® from a crate without a forklift:

1. Plug the connectors together.
2. Take 2 x 4's off the edge of the crate and between the wheels.
3. Place 2 x 4's behind the crate of the rear of the machine.
4. Make a ramp with the 2 x 4's and the crate material.
5. To enable power to the Terminator®, turn the key, pull up on the red knob.
6. Pull back the left and right handles evenly and depress the foot pedal slowly. The machine will start moving slowly backwards.
7. Ensure that both rear wheels come off the crate evenly. Failure to back off evenly could result in the machine tipping over and harm to the operator.
8. As the machine moves back, ensure that the center wheel clears the crate. If the center wheel does not clear the crate, raise the machine until the wheel clears.
9. Once the machine is on the ramp, slide it all the way to the bottom, then raise the jaw assembly up and set the center wheel down on the ground.
10. Whenever mounting or dismounting the Terminator®, ALWAYS disable the power by pressing down on the red power knob.

12. Loading/Unloading Procedures

- Do not load or unload the Terminator® on uneven ground.
- Ensure ramps into moving vehicles are stable and square to the ground.
- Always turn off the Terminator® before transporting it.
- Load and unload the machine with a properly weighted forklift or lift-gate.
- Make sure all safety stops are installed on a lift-gate before loading or unloading.
- Never position yourself under/around the machine while moving it with other machinery.
- Park the machine with the jaw completely down after loading.
- Properly secure the machine with chains, tire chocks, and other necessary tie downs.
- Never ride in a moving vehicle next to a Terminator®. It may tip, causing severe injury.

13. Operator Controls

1. Drive/Jaw Controls, Foot Pedal

The drive and jaw controls (three levers) are located to the left and right of the operator seat. The drive levers (left and right) control the direction of rotation of the rear wheels. The jaw height lever (left) controls the vertical position of the jaw assembly. The foot pedal controls the speed of the hydraulic pump. The levers only work when the foot pedal is partially depressed and the pump is running.

- Push the left and right levers forward **together** and hold them in position, then slowly depress the foot pedal to move the machine forward.
- Pull the left and right levers back **together** and hold them in position, then slowly depress the foot pedal to move the machine in reverse. (The alarm will sound)

- Push only the left lever forward to turn the machine to the right.
- Push only the right lever forward to turn the machine to the left.
- To adjust the jaw assembly down, push and hold the jaw lever forward and depress the foot pedal. To adjust the jaw assembly up, pull and hold the jaw lever back and depress the foot pedal.

2. Auto Stop

When you release the drive or jaw lever, the motor continues to run (with foot pedal depressed) but the drive or jaw motion automatically stops and will not start again until you push or pull the levers.

3. Emergency Brake

The Terminator® is supplied with an emergency brake to prevent unintended movement when left unattended. The brake handle is located to the left of the operator seat. Pull the handle up to engage the brake, push the handle down to release the brake. To increase tension on the brake you can rotate the end of the handle in a clockwise direction. Rotate the end of the handle counter clockwise to reduce the tension.

4. Power Limiter

The power limiter allows the top speed output to be set from 70% to 100%. This will allow you to conserve power during normal operation when top speed is not required.

5. Manual Disconnect and Lockout

The manual disconnect is located to the right side of the operator seat. To enable operation of the Terminator® unlock the manual disconnect lock and pull up. In case of emergency push down to remove power from all electrical components. Always push down this switch to OFF when the Terminator is not in use.

14. Display & Indicators

1. Battery Display and Hour Meter

The battery display shows pump use time, key power time, and battery life. When the last light starts to blink you have roughly 15 minutes before all power is depleted.

2. Hydraulic Oil Over Temperature Indicator

Normal temperatures are below 120°F. Do not allow the hydraulic fluid to exceed 200°F because it may damage the hydraulic system and in turn damage the Terminator®. If the indicator light is continually coming on, turn the machine off and let it cool down for 45-60 minutes. If the light is still regularly turning on, please call Innovatech.

3. Hydraulic Filter Clog Indicator

The hydraulic oil filter is equipped with a clog indicator which will illuminate when the hydraulic oil filter is clogged. The indicator may briefly illuminate in cases of extreme cold, and will turn off when the hydraulic oil was warmed to a normal operating temperature.

15. Electric Motor & Batteries

The electric motor and batteries are located under the top cover. The electric motor provides the power to the hydraulic pump to drive the Terminator®. The electric motor requires little maintenance, inspect wire connections and check for debris to maintain its efficiency and prolong its operating life.

16. Blade Assembly

Blades are available in different configurations and thickness. An assortment of blades is included in the purchase price of the Terminator®. Extra blades are available upon request from Innovatech Products & Equipment Co., Inc.

Installing a Blade:

1. Raise the jaw assembly to its maximum up position.
2. Unwrap the pre-sharpened blades and select the blade thickness and length you need for the job.
3. Loosen the 7 holding bolts.
4. Insert the sharpened blade.
5. Tighten bolts firmly, starting from the center and working out. Bolts should be snug but not over-tightened.

17. Taking Up Floor Coverings

1. Insert the blade. (See Blade Assembly)
2. Lower the jaw assembly to the floor. Lift the caster wheel off the floor 1/4 inch. Use previous procedures to drive forward.
3. As the Terminator® is removing flooring material, it is recommended to have another person at the side of the machine removing accumulating debris.

18. Ballast

The Terminator® can be equipped with weight plates in the front (38 lbs. each) and in the rear (75 lbs. each) to provide traction for tough jobs. These weights can be easily removed to reduce traction or assist in transportation. Wear gloves whenever handling the weights to reduce the risk of injury, following OSHA approved lifting techniques.

19. Tricycle or Caster Wheelbase and Tires

The tricycle wheelbase is designed for a better turning ability. The wheel bearings on the front caster roller require lubrication with grease every 30 hours of machine operation. There are three fittings, two on the wheel and one on the housing. When running over debris such as carpet, the carpet yarn will get caught between the wheel and the housing. Clean out wheel and housing regularly.

The rear tires are solid rubber, tubeless, and require no maintenance. Over time, they may wear out and need replacing. Before each job, inspect the rear tires and lug bolts. Tighten the lug bolts as needed to 70 ft.-lbs. torque – it is important to keep the lug bolts tight.

The wheel hubs should be tightened from 310 to 350 ft.-lbs. Inspect and re-torque every 60 hours of operation. Lift the machine off the floor so no weight is on the wheel when re-torquing the pack nut.

20. Battery Safety

1. Receiving the Terminator®

After receiving the Terminator®, examine the covers and battery catch tray for signs of damage. Attention should be given to the crate and pallet of the Terminator® when it arrives for any damage that may have happened during shipment. If you see any dented or crushed housing parts contact Innovatech for procedures to repair shipping damage.

Only trained or authorized personnel should change, repair, or charge batteries. When used properly, a lead-acid battery is a safe, dependable source of electrical power. However, if proper care and safety precautions are not exercised when handling a battery, it can be a dangerous piece of equipment.

2. Hazardous Elements

Although the T-3000XME is supplied with sealed, absorbed electrolyte batteries, there is a potential for leakage of acid in catastrophic damage situations. The electrolyte in a lead-acid storage battery is a diluted solution of water and sulphuric acid. Although the acid content in the solution is an estimated 37%, it is still a strong corrosive agent and can burn skin and eyes as well as dissolve many types of fabric. (See Wearing Protective Clothing)

When a lead-acid battery is being charged, it produces small amounts of hydrogen and oxygen, a potentially explosive mixture. Never smoke, use an open flame, or create an arc or sparks on or near the battery without first dispersing the explosive gases from the cells you are working on. (See Setting Up a Charging Area)

An electrical shock hazard exists whenever improperly handling the batteries and their cell connectors. Metallic objects that come into contact with the exposed connectors can cause a short circuit that will heat the objects to very high temperatures. Even shorts involving a single cell can become hot enough to cause severe burns. Any tools used on or around the T-3000XME should be covered with a plastic coating or heat shrink.

3. Lifting Batteries

Always use proper lifting equipment to reduce the risk of battery damage, shorting and possible injury. An insulated lifting device used with an overhead hoist is the safest way to move a battery. Chain hoists used to handle batteries should be equipped with a non-metallic container or bucket to prevent the chains from dangling and possibly causing a short by coming in contact with exposed cell connectors on the top of the battery.

Never lift batteries by the inter-cell connecting cables, the connectors will come apart while the battery is in midair. Connectors on these cables are designed for maximum

current flow, not strength. Connect the lifting device to the negative terminal only if there is not a lifting strap in place. Lifting by both terminals could cause the negative and positive terminals to short.

4. Wear Protective Clothing

When working on or near batteries, always wear proper protective clothes including a face shield, safety glasses, long sleeved shirt, and acid-resistant gloves. Do not wear any metal jewelry including rings, as they can short circuit a battery and become extremely hot if it accidentally contacts exposed intercell connectors.

21. Setting Up a Charging Area

All owners of the Terminator® need to designate a charging area to charge the battery pack at the end of a workday or while storing the Terminator®. This area should have all the proper battery handling equipment and be well ventilated, even for trickle-charge scenarios. Ventilation is considered satisfactory if the hydrogen concentration does not exceed 1.5-2% in any one location. Concentrations above 4% are explosive and dangerous.

Factors determining proper ventilation include the number of Terminator® machines or other battery-operated machinery such as forklifts that are stored in the location, as well as the size, height, and air-tightness of the storage location.

Many instruments, such as combustible gas indicators and flammable vapor indicators, are available for continuous and automatic analysis of hydrogen content in the air. A floor standing fan or box fan will significantly help to disperse off-gassing.

A source of running water is desirable, preferably a water hose at the charging and filling station(s). The floor in the battery charging and filling area(s) should have an acid resistant coating and be able to be washed down with clean water after a spill. The spill should be neutralized with baking soda or soda ash before it is cleaned up. While these products are relatively safe to handle, the chemical reaction with the spill will produce carbon dioxide, a heavy gas that tends to collect in low places if not properly ventilated.

Carbon dioxide is a non-toxic gas on its own, but if its presence dilutes the oxygen content of the air from the normal 21% to 16% or below, breathing in that air can cause injury or death. Proper ventilation will control this hazard in open spaces, although extra care should be taken when neutralizing significant quantities of sulphuric acid in closed areas.

Neutralizing sulphuric acid with lime, caustic soda, or ammonium hydroxide will not produce carbon dioxide but are dangerous chemicals themselves, and should ONLY be handled by qualified, chemically trained individuals.

1. Connecting/Disconnecting Charger

Always turn the charger off at the charging unit before connecting or disconnecting the battery charger leads. The connectors in the battery compartment are shipped in a disconnected state; these will have to be plugged in for the Terminator® to operate.

Live leads can cause arcing and sparks which could cause an explosion if battery gases are present, please check that the main contactor/disconnector is not in the on condition when you connect or disconnect the battery terminal plug. In addition, the battery

connector terminals will become pitted over time resulting in poor connections and increased heat generation in the battery leads and connectors.

2. Basic Charging Facts

- Proper charging is essential for maximum battery life.
- When a discharged battery is initially placed on charge, it will draw a current equal to or close to the charger's maximum output. As the battery voltage rises back to its rated voltage the charger's output will adjust down automatically to assure a safe, efficient charging rate during all stages of the charge.

22. Maintenance Procedures

1. Grease Caster Wheel at three fittings every 30 hours.
2. Check Hydraulic Oil once a month. Change every 18 months with NUTO H 46 or ISO 46 or if fluid is overheated 200°F or higher.
3. Change hydraulic filter every 60 hours.
4. Clean Caster Wheel and Back Tires with wire wheel when necessary.
5. Look for leaks, find and tighten fittings. Do not over-tighten fittings.
6. Check all hoses and clamps once a week.
7. Inspect rear tires and lug bolts. Tighten lug bolts as needed to 70 ft.-lbs. torque.
8. Check wheel hub every 60 hours of operation. Wheel hub pack nut should be torqued from 310 to 350 ft.-lbs.

23. Parts List

T-3000XME Terminator

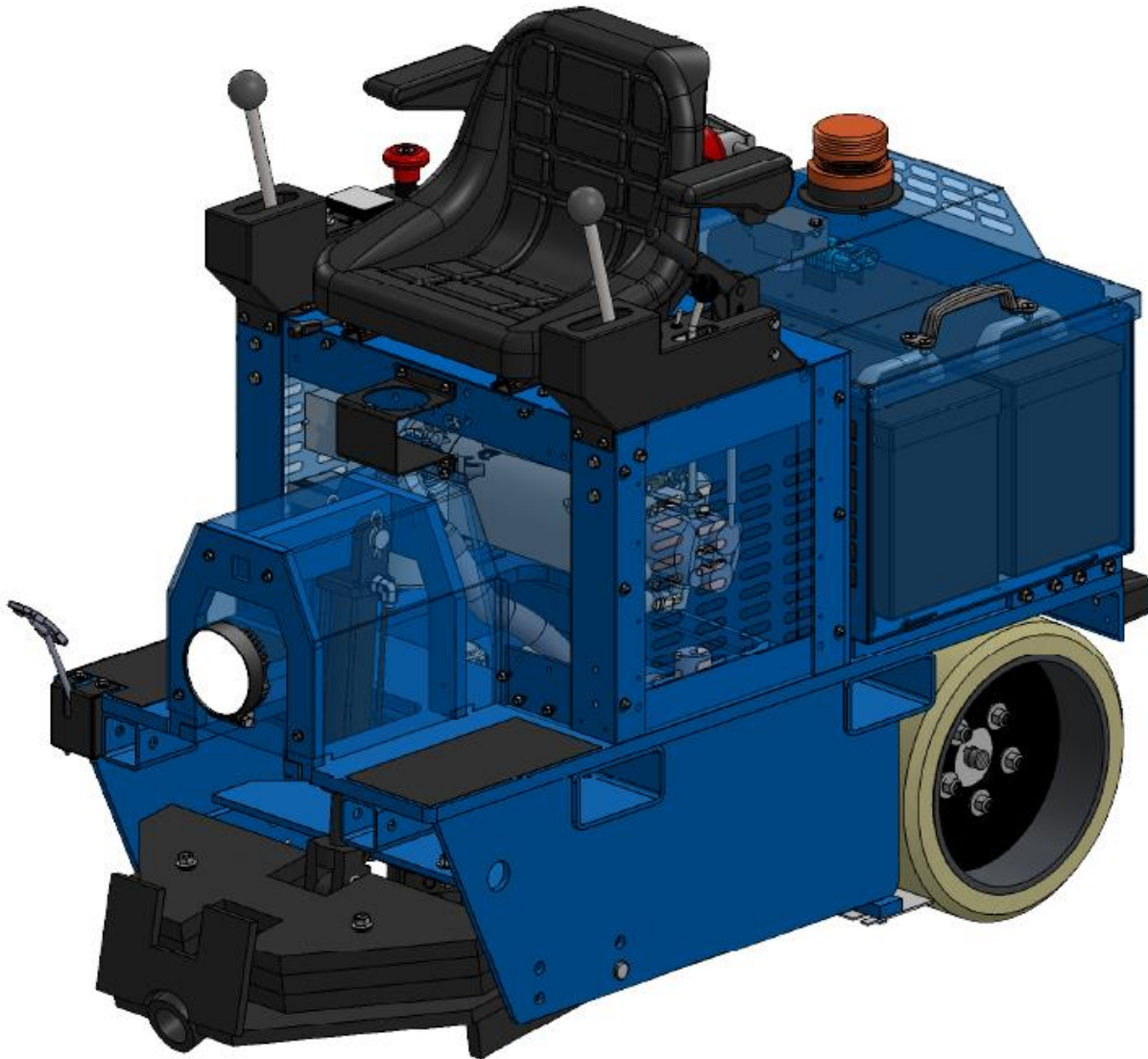

Front Exterior (1) Breakdown

Item No.	Part Number	Description	Qty.
101	12-0043-16	Serrated Flange Cap Screw, M6-1.0 x 16mm	16
102	22-0065	LED Headlight, 4 1/2"	1
103	53-0363	Uni-Frame Assembly	1
104	53-0376	Uni-Frame Cup Holder	1
105	53-0381	XME Front Console	1
106	96-0332	Front Jaw Assembly	1

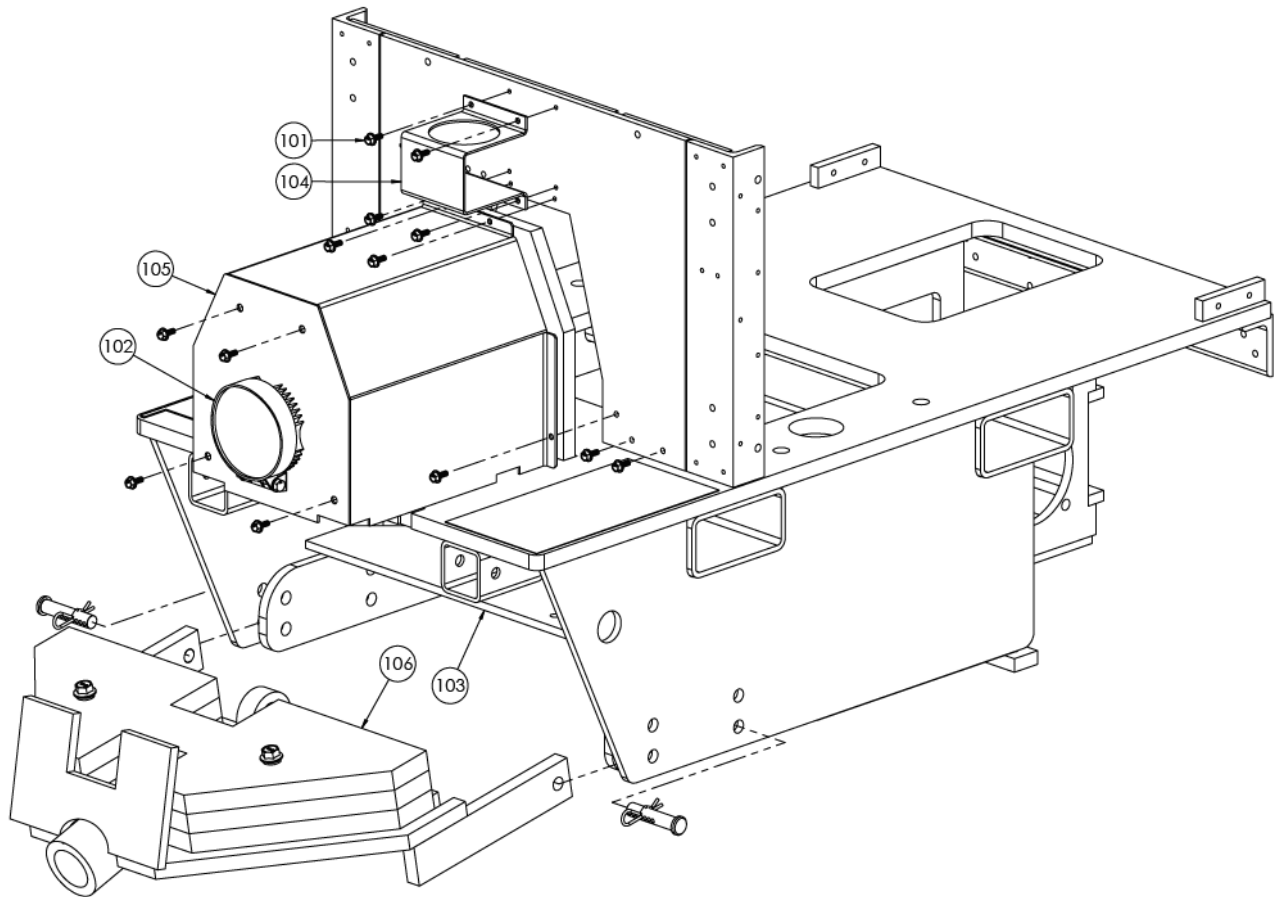

Front Exterior (2) Breakdown

Item No.	Part Number	Description	Qty.
201	11-0024	Nyloc Nut, 1/4"-20	3
202	11-0033	USS Flat Washer, 1/4"	3
203	11-0035	USS Flat Washer, 3/8"	8
204	11-0052	Hitch Pin	4
205	11-0069	Lock Washer, 1/4"	3
206	11-0121	Hex Head Cap Screw, 1/4"-20 x 1"	3
207	11-0133	Hex Head Cap Screw, 1/4"-20 x 3/4"	3
208	12-0021-10	Nyloc Nut, M10-1.5	4
209	12-0034-40	Hex Head Cap Screw, M10-1.5 x 40mm	4
210	13-0041	Caster Wheel Replacement	1
211	23-0125	Foot Pedal	1
212	31-0043	Hydraulic Fitting, 90 deg 4 JIC – 8 SAE	2
213	34-0008	Hydraulic Ram	1
214	53-0386	Foot Pedal Bracket	1

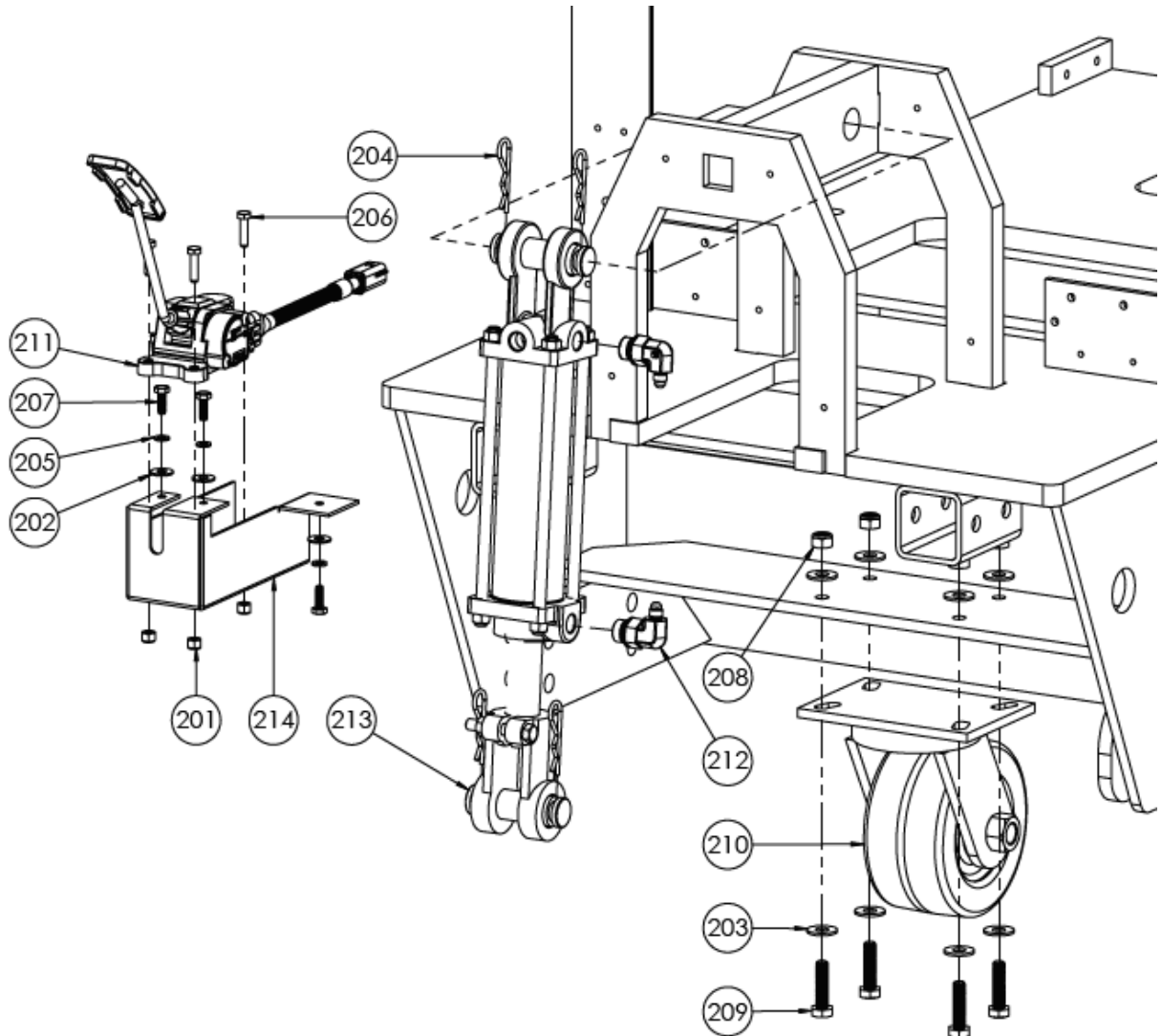

Interior (1) Breakdown

Item No.	Part Number	Description	Qty.
301	11-0069	Lock Washer, 1/4"	2
302	11-0092	Hex Head Cap Screw, 1/4"-20 x 1/2"	2
303	12-0043-16	Serrated Flange Cap Screw, M6-1.0 x 16mm	2
304	12-0051	Socket Head Cap Screw, M5-0.8 x 12mm	2
305	23-0114	Foot Pedal Power Supply	1
306	24-0199	48-12VDC Converter	1
307	31-0051	Hydraulic Fitting, 90 deg 12 JIC – 12 SAE	1
308	31-0052	Hydraulic Fitting, 90 deg 10 JIC – 12 SAE	1
309	35-0037	Hydraulic Oil Filter Replacement	1
310	53-0398	Uni-Frame Filter Bracket	1

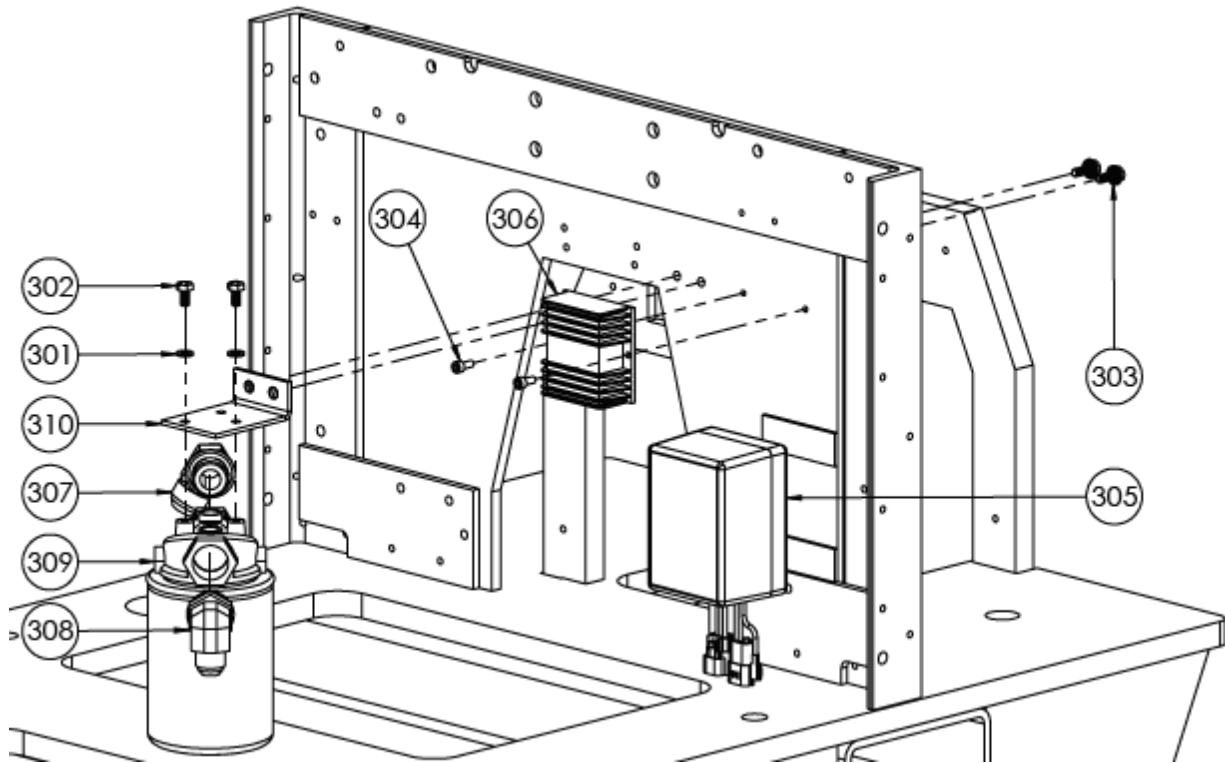

Interior (2) Breakdown

Item No.	Part Number	Description	Qty.
401	11-0025	Nyloc Nut, 5/16"-18	8
402	11-0034	USS Flat Washer, 5/16"	16
403	11-0129	Lock Washer, 3/8"	2
404	11-0132	Hex Head Cap Screw, 5/16"-18 x 1"	4
405	11-0139	SAE Flat Washer, 5/16"	2
406	11-0175	Hex Head Cap Screw, 5/16"-16 x 2"	4
407	11-0295-20	Hex Head Cap Screw, 3/8"-24 x 1 1/4"	2
408	23-0002	Electric Motor, 48V	1
409	24-0182-19	Power Pack Display Harness	1
410	31-0038	Hydraulic Fitting, 90 deg 10 JIC – 10 SAE	1
411	31-0051	Hydraulic Fitting, 90 deg 12 JIC – 12 SAE	1
412	33-0021	XME Gear Pump, 11CC	1
413	53-0356	XME Weld Assembly	1
414	96-0345	Power Control Module	1

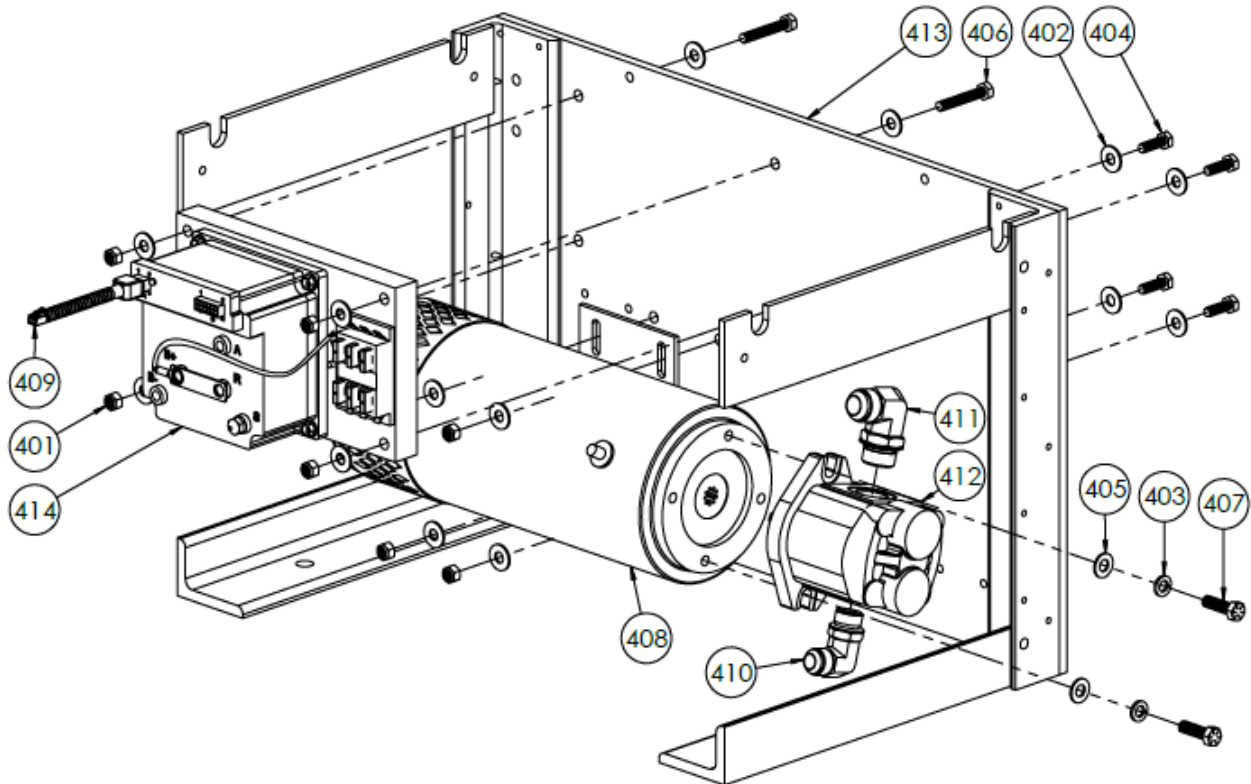

Panels & Weld Assembly Breakdown

Item No.	Part Number	Description	Qty.
501	11-0012	Hex Head Cap Screw, 1/2"-13 x 2"	4
502	11-0028	Nyloc Nut, 1/2"-13	4
503	11-0230	USS Flat Washer, 1/2"	8
504	12-0043-16	Serrated Flange Cap Screw, M6-1.0 x 16mm	20
505	12-0044-20	Serrated Flange Cap Screw, M8-1.25 x 20mm	2
506	53-0356	XME Weld Assembly	1
507	53-0380	XME Side Panel	2
508	53-0383	XME Front Panel	1
509	53-0397	Uni-Frame Seat Mounting Bracket	4

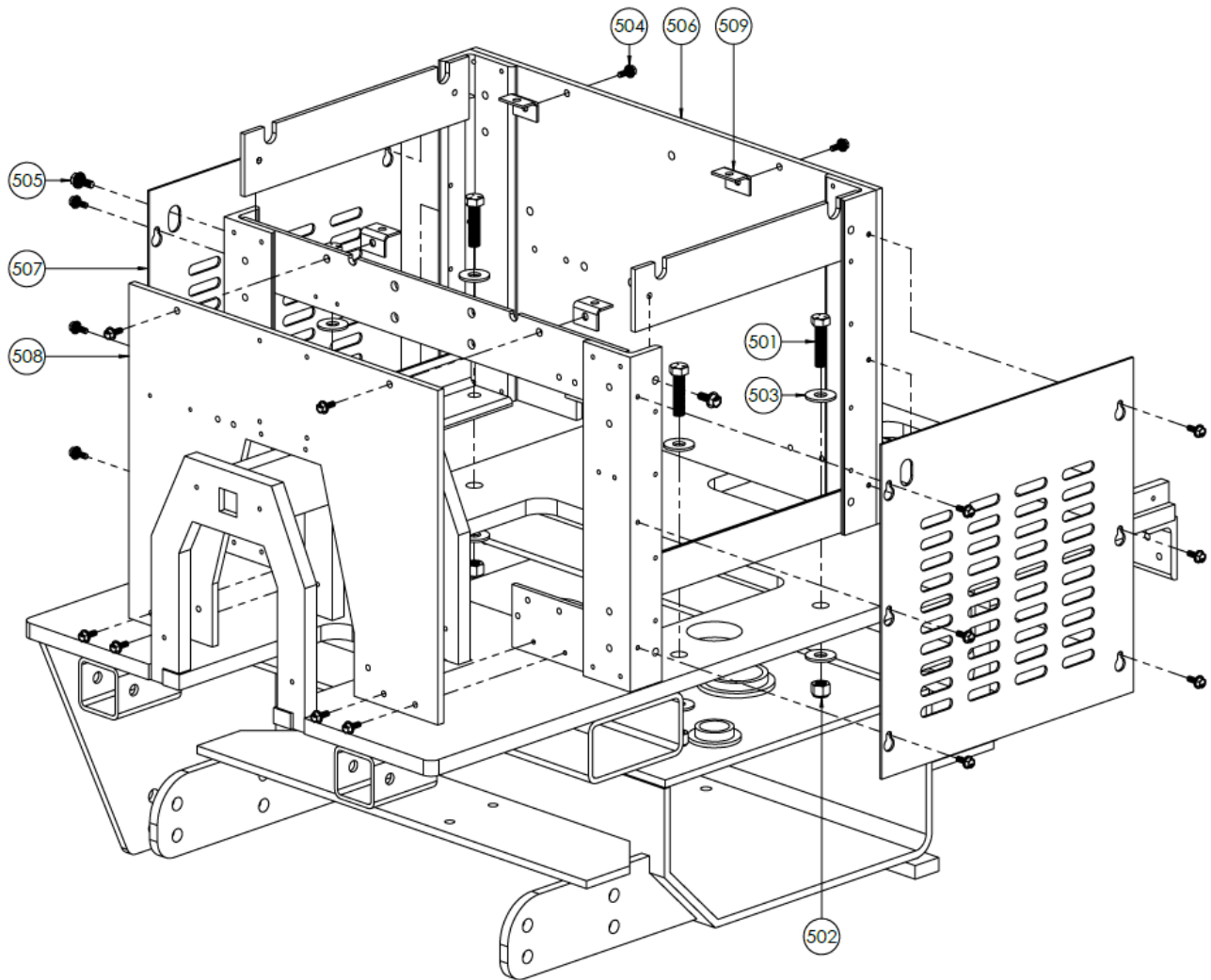

Seat & Consoles Breakdown

Item No.	Part Number	Description	Qty.
601	12-0018-06	Lock Washer, M6	4
602	12-0026	Hex Head Cap Screw, M6-1.0 x 12mm	4
603	12-0043-16	Serrated Flange Cap Screw, M6-1.0 x 16mm	12
604	13-0049	GT50 Seat	1
605	96-0359	XME Right Console Assembly	1
606	96-0370	Uni-Frame Left Console Assembly	1
607	96-0393	XME Seat Platform Assembly	1

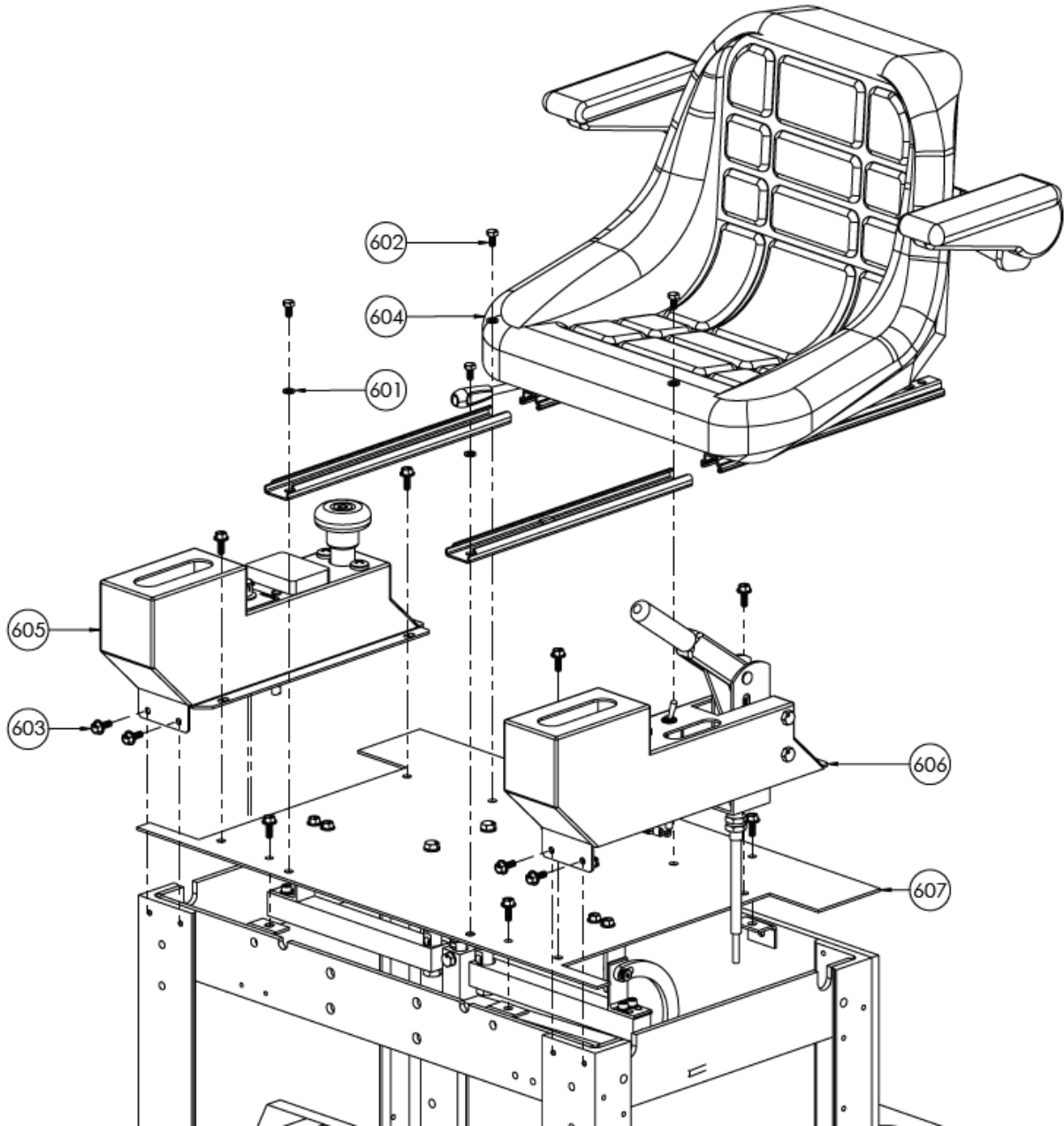

Valve Block Breakdown

Item No.	Part Number	Description	Qty.
701	22-0007	Oil Temperature Switch	1
702	31-0022	Hydraulic Fitting, Flow Reducer 4 JIC – 6 SAE	1
703	31-0024	Hydraulic Fitting, 4 JIC – 6 SAE	1
704	31-0045	Hydraulic Fitting, 8 SAE – 1/4" NPTF	1
705	31-0048	Hydraulic Fitting, 90 deg 10 JIC – 8 SAE	2
706	31-0056	Hydraulic Fitting, 90 deg 6 JIC – 6 SAE	4
707	35-0050	3-Section Hydraulic Control Valve	1

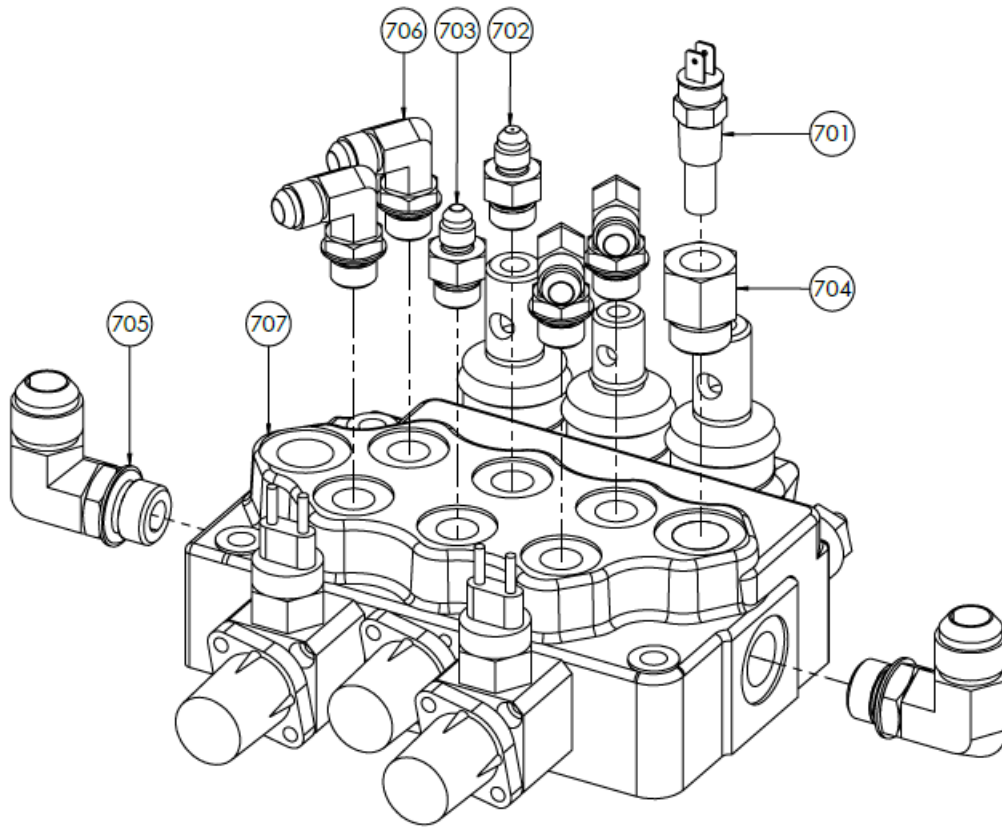

Linkages Breakdown

Item No.	Part Number	Description	Qty.
801	11-0024	Nyloc Nut, 1/4"-20	2
802	11-0040	Lock Washer, 5/16"	2
803	11-0067	Hex Nut, 5/16"-18	2
804	11-0073	Cotter Pin	2
805	11-0175	Hex Head Cap Screw, 5/16"-18 x 2"	2
806	11-0232	Fender Washer, 5/16"	2
807	11-0277	Clevis Pin, 5/16" x 1"	2
808	11-0294-16	Socket Head Shoulder Screw, 5/16" x 1", 1/4"-20	2
809	11-0303	Triple Wave Washer, 1/4" - 5/16"	4
810	11-0352	Hex Jam Nut, 5/16"-24	2
811	12-0018-08	Lock Washer, M8	4
812	12-0018-10	Lock Washer, M10	1
813	12-0021-08	Nyloc Nut, M8-1.25	4
814	12-0027-10	Hex Nut, M10-1.5	2
815	12-0032-30	Hex Head Cap Screw, M8-1.25 x 30mm	4
816	12-0035-08	Flat Washer, M8	4
817	13-0300	Knob, SØ 1 7/8", 5/8"-11	2
818	13-0380	Linkage Yoke End	2
819	13-0381	Linkage Rod End	2
820	13-0383	Knob, SØ 35mm, M10-1.5	1
821	51-0699	Yoke Anchor	2
822	53-0257	Jaw Rod with Welded Washer	1
823	52-0389	Uni-Frame Joy Stick Rod	2
824	96-0393	XME Seat Platform Assembly	1

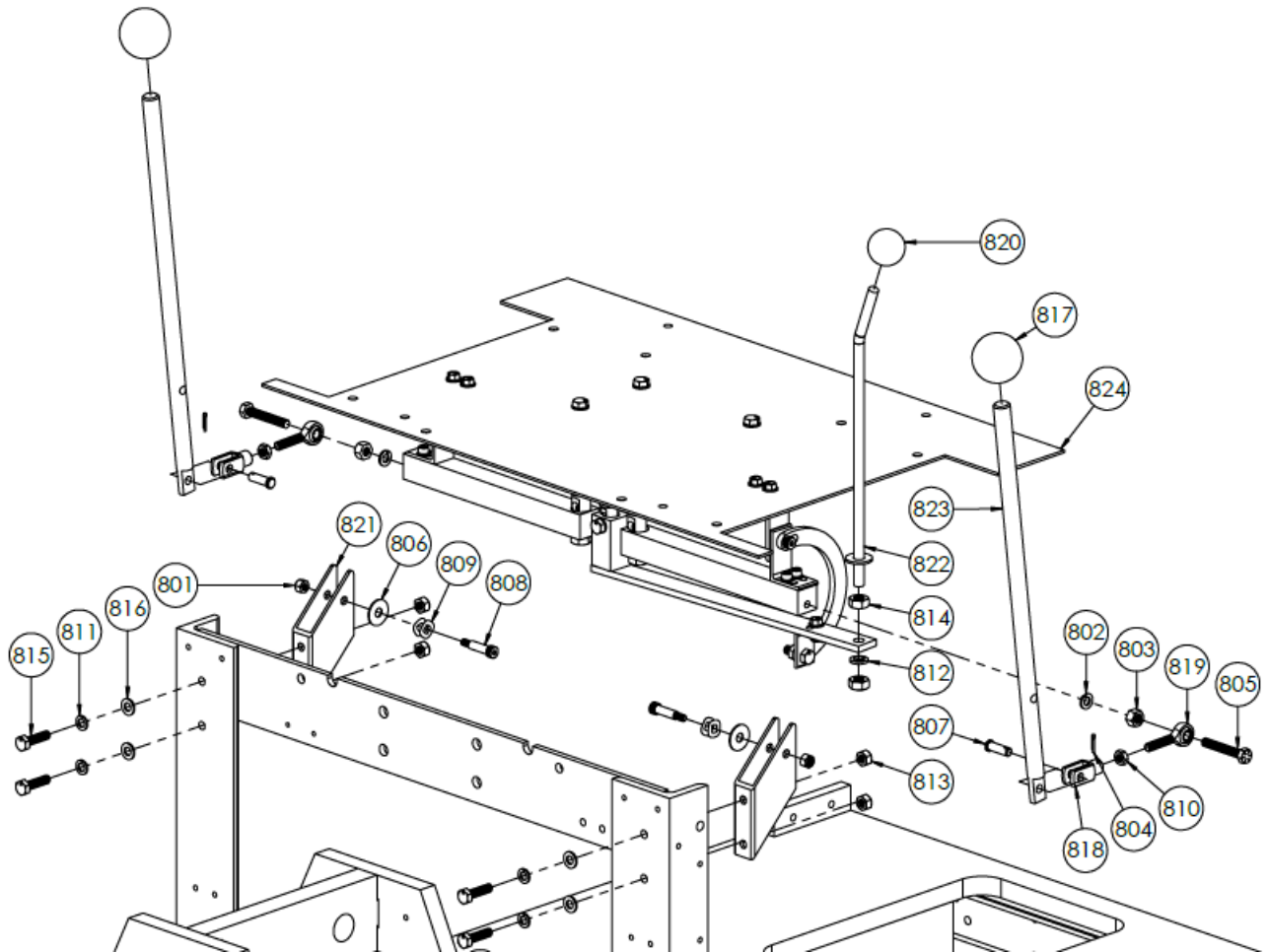

Tank Fittings Breakdown

Item No.	Part Number	Description	Qty.
901	31-0025	Hydraulic Fitting, Straight 12 JIC – 1" NPT	1
902	31-0124	Threaded Tank Fitting, 2" Male, 1" x 1" Female	2
903	31-0128	Hydraulic Fitting, 90 deg 12 JIC – 1" NPTF Male	1
904	31-0252	Hex Head Pipe Plug, 2" NPT	1
905	35-0004	Pipe Nipple, 1" NPT x 6" L	2
906	35-0051	Drain Plug, M14-1.5	1
907	35-0052	Hydraulic Breather Cap	1
908	53-0159	XME Dip Stick	1

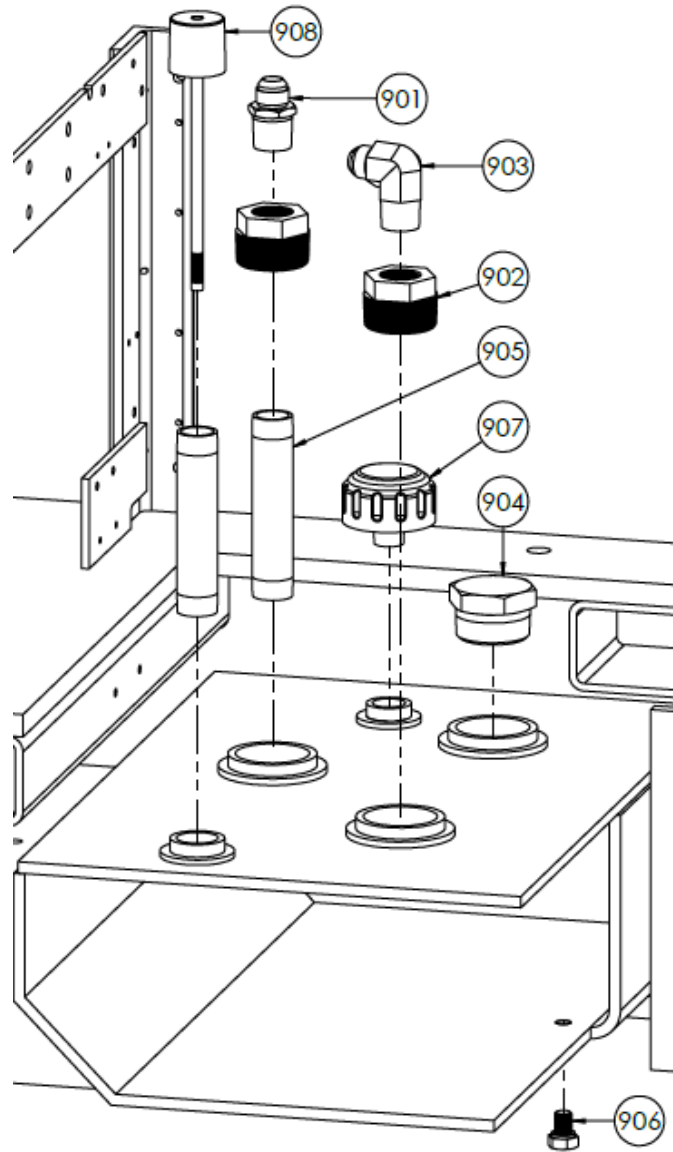

Battery Area Breakdown

Item No.	Part Number	Description	Qty.
1001	12-0032-30	Hex Head Cap Screw, M8-1.25 x 30mm	2
1002	12-0035-08	Flat Washer, M8	2
1003	12-0044-20	Serrated Flange Cap Screw, M8-1.25 x 20mm	8
1004	53-0356	XME Weld Assembly	1
1005	53-0404	XME Battery Box Connector	2
1006	53-0408	XME Battery Box Spacer	1
1007	71-0016	XME Battery Pack Unit	2
1008	96-0339	XME Battery Box	1

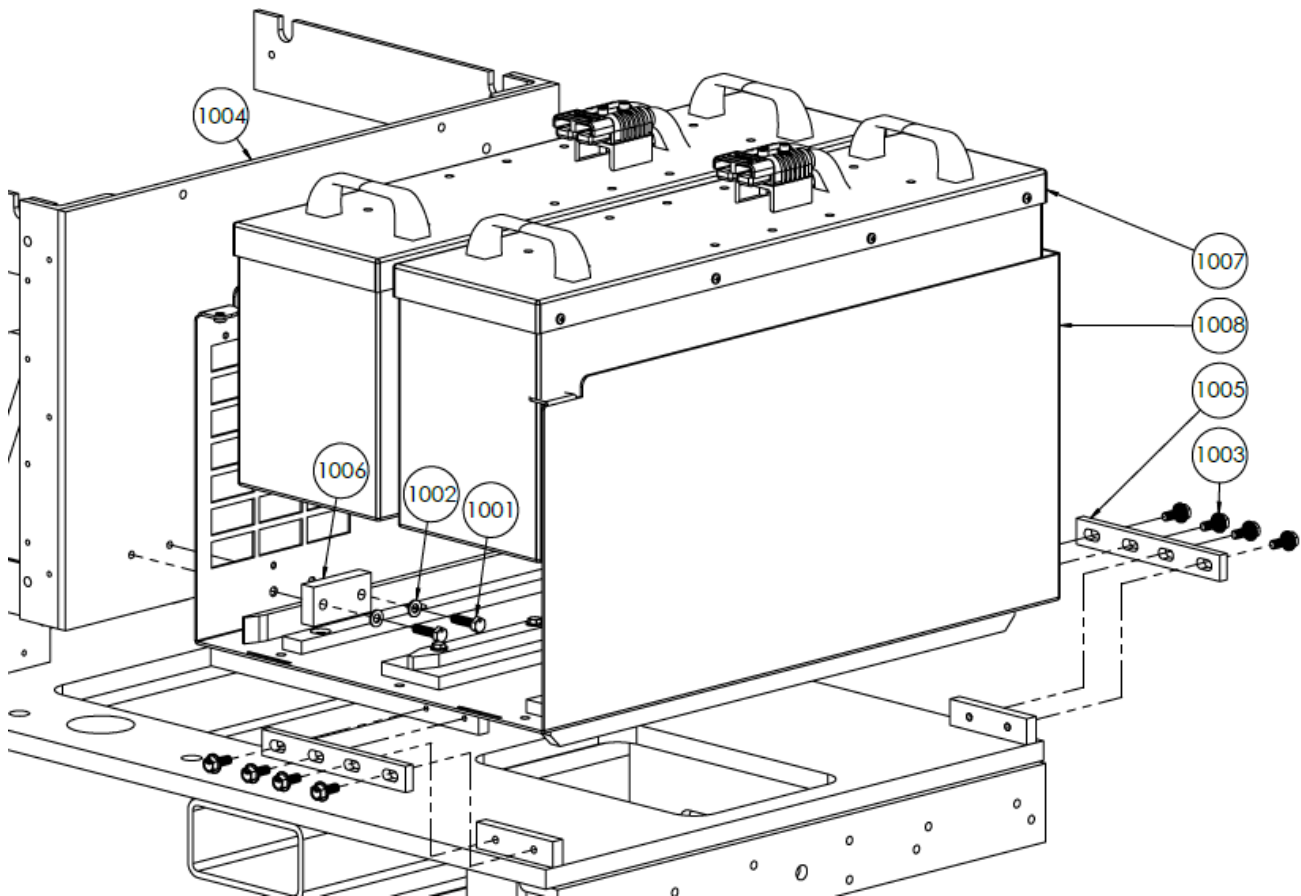

Rear Wheels Breakdown

Item No.	Part Number	Description	Qty.
1101	11-0008	Hex Head Cap Screw, 3/8"-16 x 1 1/2"	4
1102	11-0024	Nyloc Nut, 1/4"-20	2
1103	11-0033	USS Flat Washer, 1/4"	2
1104	11-0035	USS Flat Washer, 3/8"	4
1105	11-0129	Lock Washer, 3/8"	8
1106	11-0130	Hex Head Cap Screw, 3/8"-16 x 3/4"	8
1107	11-0279-88	Hex Head Cap Screw, 1/4"-20 x 5 1/2"	2
1108	11-0304	Socket Head Shoulder Screw, 5/16" x 5/8", 1/4"-20	2
1109	11-0353	Set Screw, #10-32 x 3/8"	1
1110	13-0384	Rear Bumper	2
1111	51-0513	Cable Clamp	1
1112	53-0134	Brake Actuator	1
1113	81-0091	Wheel Scraper Blade, 7.5" x 4.5"	2
1114	96-0387	XME Left Wheel Assembly	1
1115	96-0388	XME Right Wheel Assembly	1

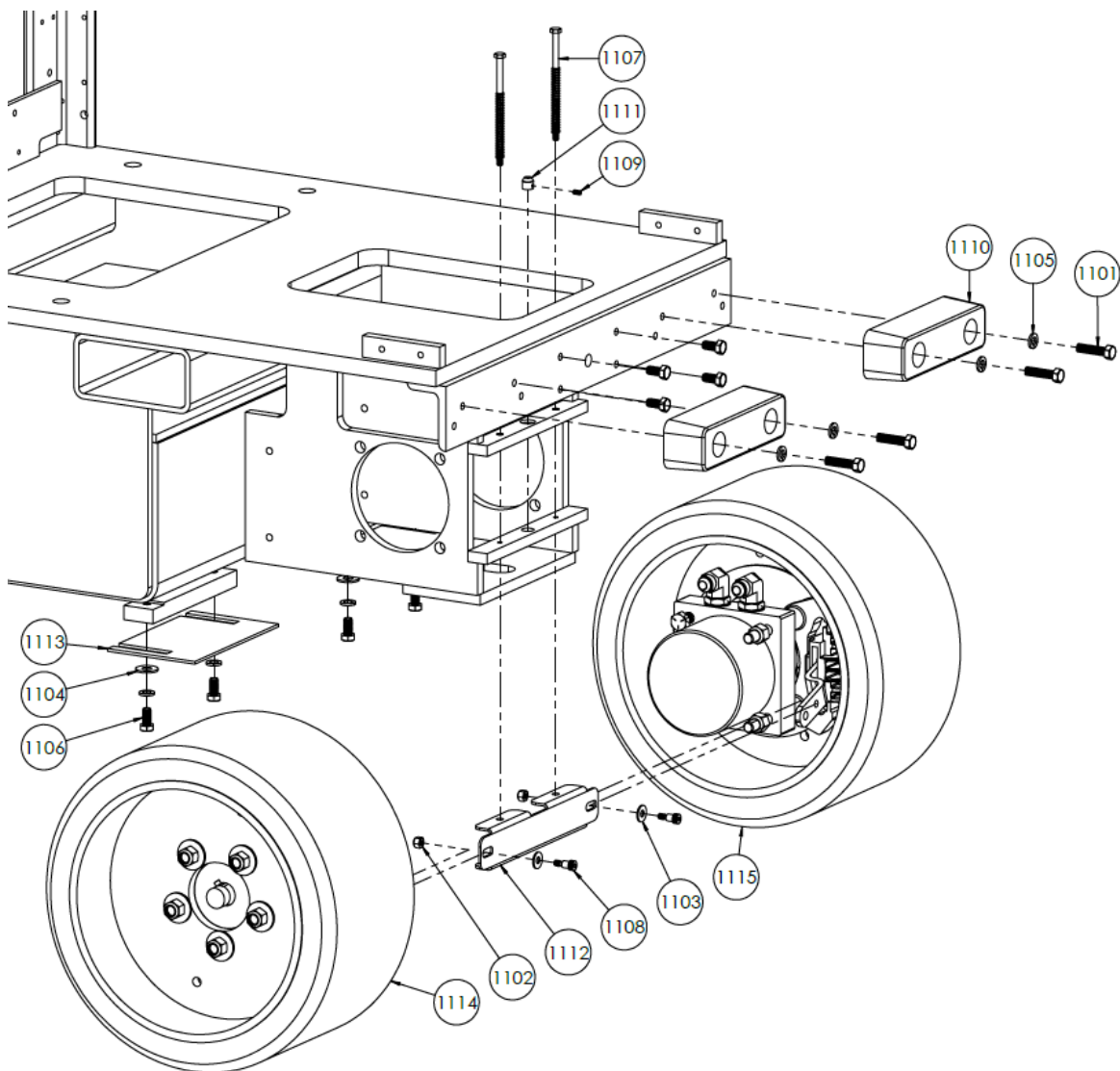

XME Seat Platform Assembly - Part # 96-0393

Item No.	Part Number	Description	Qty.
1201	11-0304	Socket Head Shoulder Screw, 5/16" x 5/8", 1/4"-20	1
1202	11-0306	Socket Head Shoulder Screw, 5/16" x 3/8", 1/4"-20	1
1203	12-0021-08	Nyloc Nut, M8-1.25	3
1204	12-0035-08	Flat Washer, M8	3
1205	12-0049-65	Hex Head Cap Screw, M8-1.25 x 65mm	3
1206	31-0048	Hydraulic Fitting, 90 deg 10 JIC – 8 SAE	2
1207	35-0050	3-Section Hydraulic Control Valve	1
1208	53-0384	XME Seat Platform	1
1209	96-0354	Uni-Frame Joy Stick Linkage	2
1210	96-0355	Uni-Frame Jaw Linkage	1

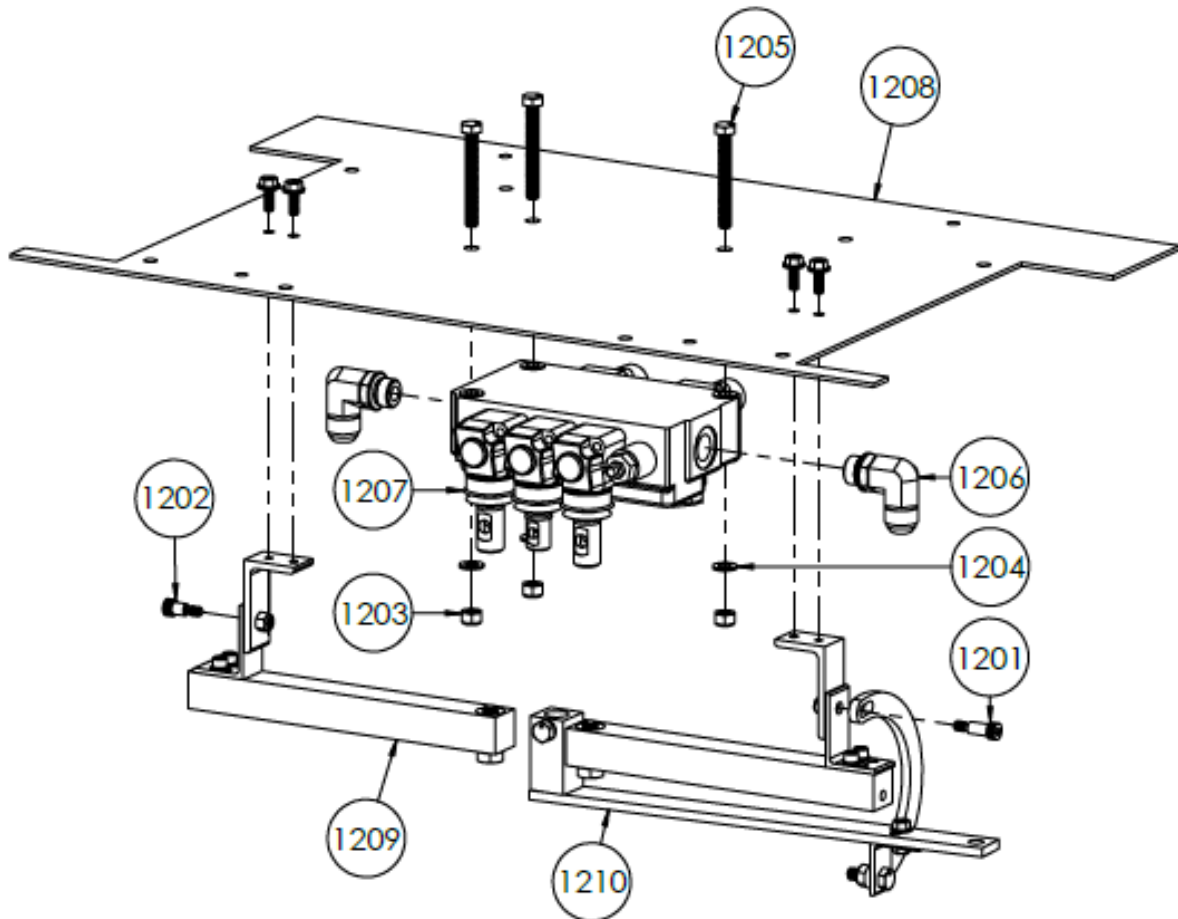

XME Right Wheel Assembly - Part # 96-0388

Item No.	Part Number	Description	Qty.
1301	11-0013	Hex Head Cap Screw, 1/2"-13 x 3"	2
1302	11-0014	Hex Head Cap Screw, 1/2"-13 x 4 1/2"	2
1303	11-0028	Nyloc Nut, 1/2"-13	4
1304	11-0029	Nyloc Nut, 1/2"-20	5
1305	11-0230	USS Flat Washer, 1/2"	5
1306	13-0021	Right Brake Caliper	1
1307	13-0022	Brake Mounting Bracket	1
1308	31-0053	Hydraulic Fitting, 90 deg 8 JIC – 10 SAE	2
1309	33-0006	XME Right Wheel Motor	1
1310	51-0481	XME Brake Spacer Standoff	2
1311	53-0209	XME Wheel and Tire Assembly	1
1312	70-0016	Wheel Hub with Brake Disc	1

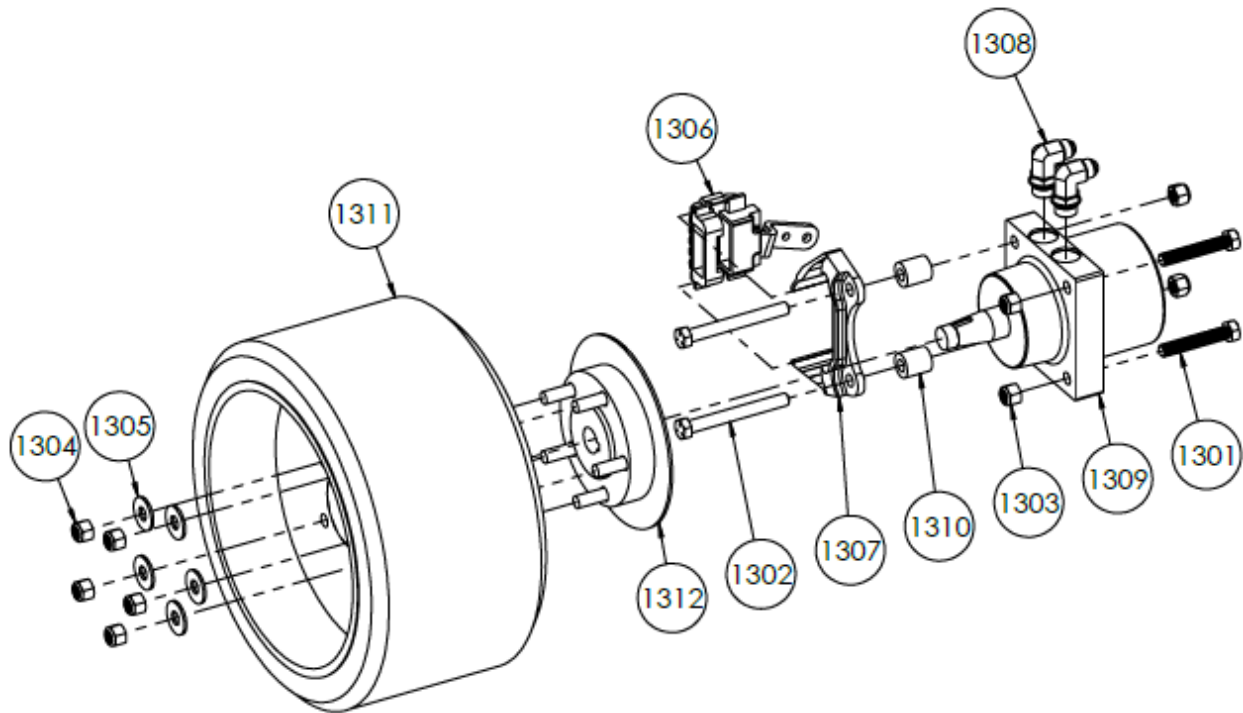

XME Left Wheel Assembly - Part # 96-0387

Item No.	Part Number	Description	Qty.
1401	11-0013	Hex Head Cap Screw, 1/2"-13 x 3"	2
1402	11-0014	Hex Head Cap Screw, 1/2"-13 x 4 1/2"	2
1403	11-0028	Nyloc Nut, 1/2"-13	4
1404	11-0029	Nyloc Nut, 1/2"-20	5
1405	11-0230	USS Flat Washer, 1/2"	5
1406	13-0020	Left Brake Caliper	1
1407	13-0022	Brake Mounting Bracket	1
1408	31-0053	Hydraulic Fitting, 90 deg 8 JIC – 10 SAE	2
1409	33-0005	XME Left Wheel Motor	1
1410	51-0481	XME Brake Spacer Standoff	2
1411	53-0209	XME Wheel and Tire Assembly	1
1412	70-0016	Wheel Hub with Brake Disc	1

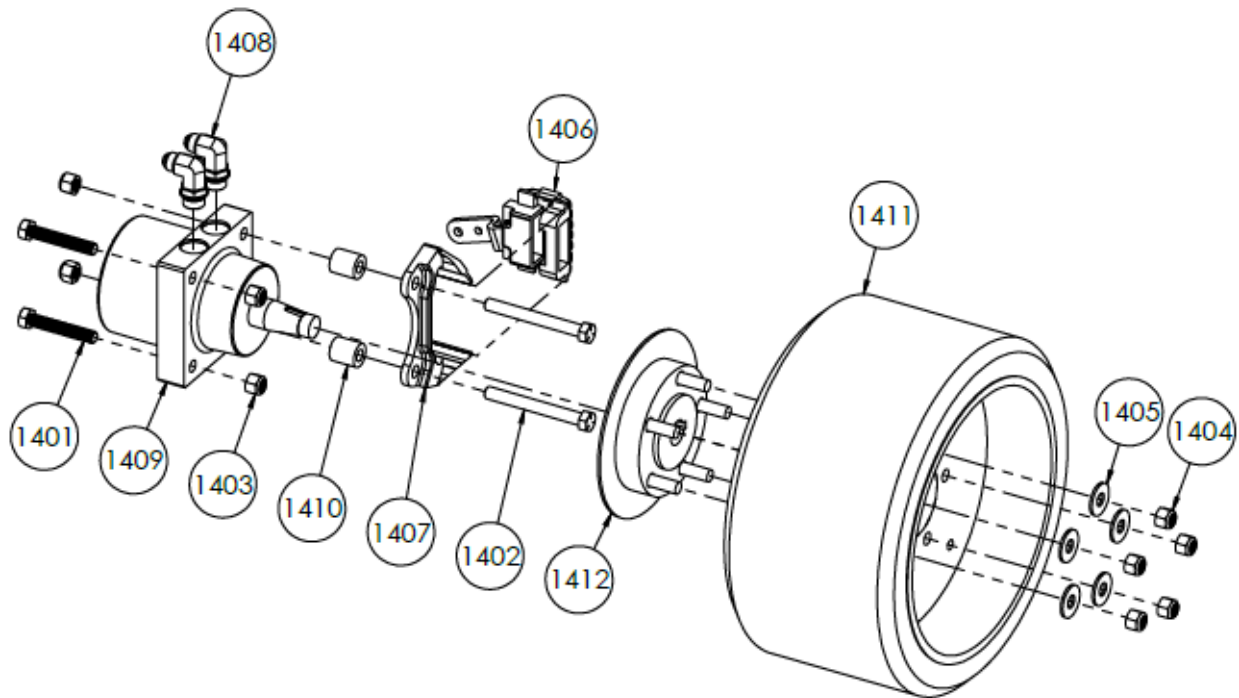

Uni-Frame Left Console Assembly - Part # 96-0370

Item No.	Part Number	Description	Qty.
1501	12-0021-08	Nyloc Nut, M8-1.25	2
1502	12-0049-90	Hex Head Cap Screw, M8-1.25 x 90mm	2
1503	13-0023	Blake Cable	1
1504	13-0027	Brake Cable Clevis	1
1505	13-0050	Brake Lever	1
1506	23-0152	USB Charging Port	1
1507	24-0200	Toggle Switch	1
1508	25-0034	Spade Connector, Female, 16-14ga	2
1509	25-0051	Spade Connector, Male, 16-14ga	2
1510	53-0379	Uni-Frame Left Console	1

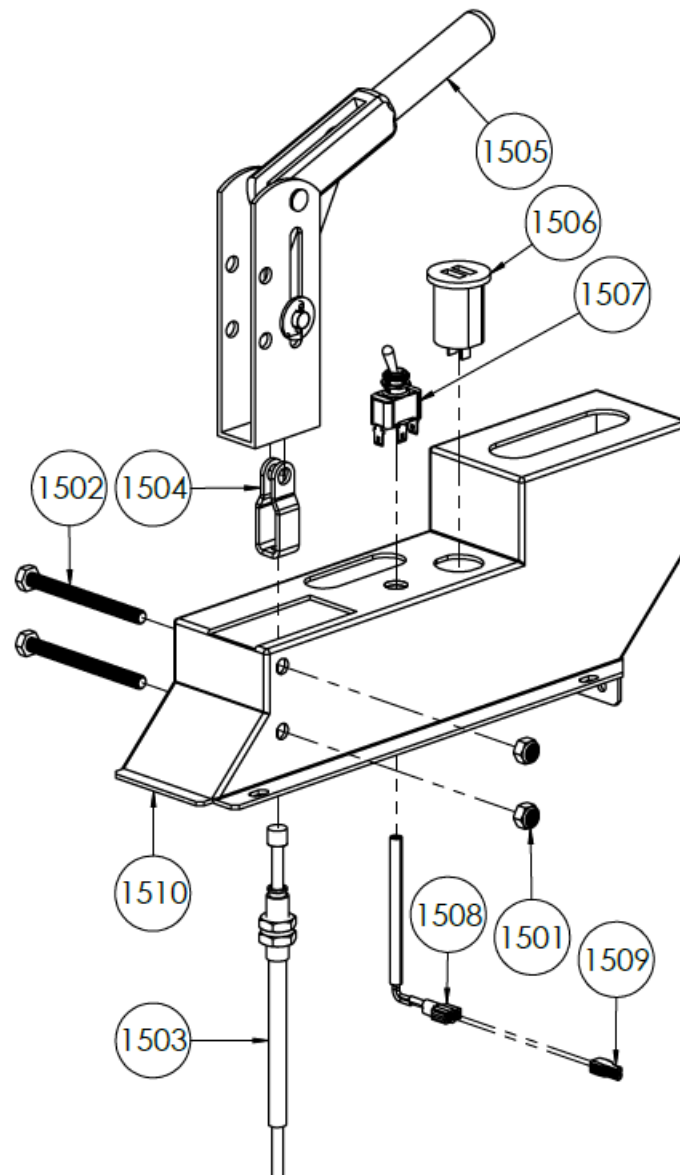

XME Right Console Assembly - Part # 96-0359

Item No.	Part Number	Description	Qty.
1601	23-0030-1	S.T.D. Display	1
1602	23-0031	Manual Disconnect Switch	1
1603	24-0164-P	Uni-Frame Right Console Wire Harness	1
1604	24-0195	XME Wire Assembly, Batt. Box to Disconnect	1
1605	24-0197	XME Wire Assembly, Disconnect to Power Pack	1
1606	25-0002	Red Panel Light	2
1607	25-0135	Bullet Connector, Male, 22-18ga	2
1608	25-0136	Bullet Connector, Female, 22-18ga	2
1609	53-0378	Uni-Frame Right Console	1

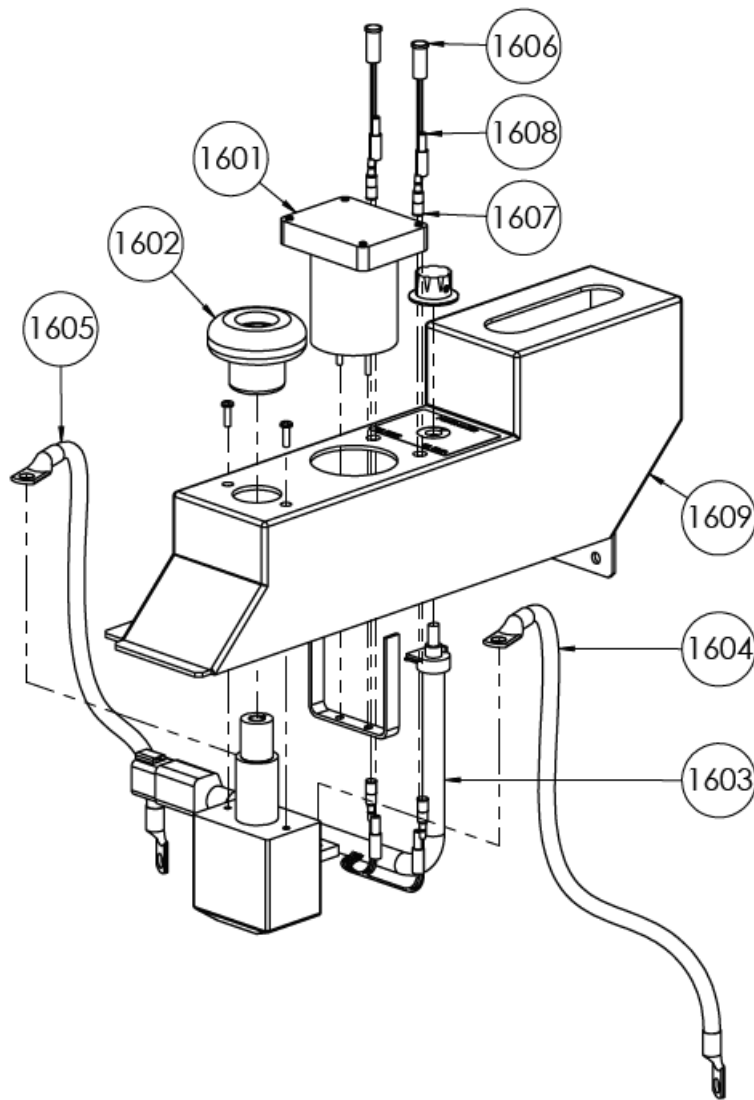

Uni-Frame Jaw Linkage - Part # 96-0355

Item No.	Part Number	Description	Qty.
1701	11-0307	Shim Washer, 5/16" ID x 7/16" OD x 0.32"	1
1702	12-0018-08	Lock Washer, M8	1
1703	12-0021-06	Nyloc Nut, M6-1.0	1
1704	12-0021-08	Nyloc Nut, M8-1.25	1
1705	12-0032-25	Hex Head Cap Screw, M8-1.25 x 25mm	2
1706	12-0043-16	Serrated Flange Cap Screw, M6-1.0 x 16mm	1
1707	51-0708	Uni-Frame Jaw Linkage Connector Hinge	1
1708	53-0367	Uni-Frame Jaw Linkage Base	1
1709	53-0390	Uni-Frame Jaw Linkage Connector	1

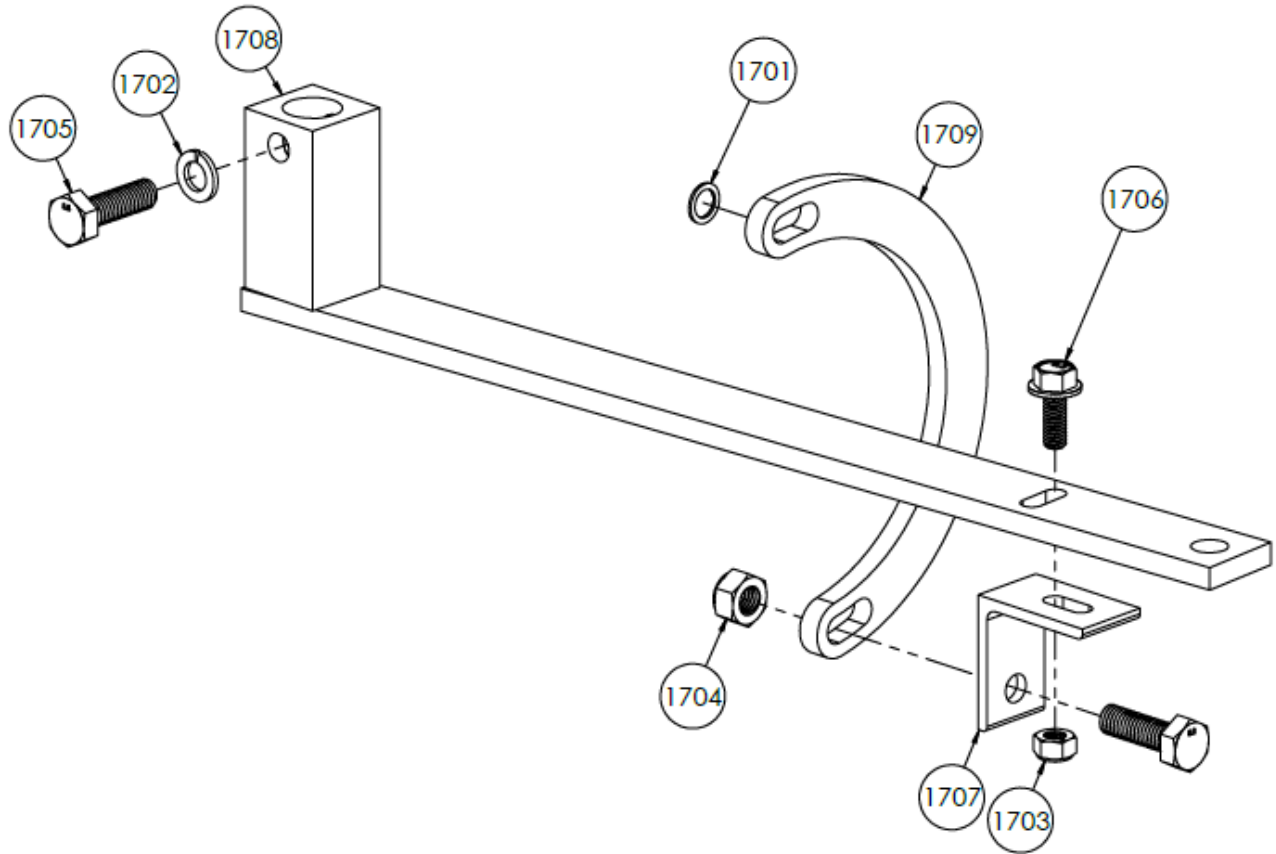

Uni-Frame Joy Stick Linkage - Part # 96-0354

Item No.	Part Number	Description	Qty.
1801	11-0024	Nyloc Nut, 1/4"-20	1
1802	11-0162	Belleville Washer, 3/8"	1
1803	11-0164	Socket Head Cap Screw, 1/4"-20 x 1/2"	2
1804	11-0307	Shim Washer, 5/16" ID x 7/16" OD x 0.32"	1
1805	12-0024	Hex Head Cap Screw, M10-1.5 x 30mm	1
1806	12-0035-06	Flat Washer, M6	2
1807	12-0043-16	Serrated Flange Cap Screw, M6-1.0 x 16mm	2
1808	51-0704	Uni-Frame Joy Stick Linkage Hinge	1
1809	51-1037	Uni-Frame Joy Stick Linkage Seat Bracket	1
1810	53-0401	Uni-Frame Joy Stick Linkage Base	1

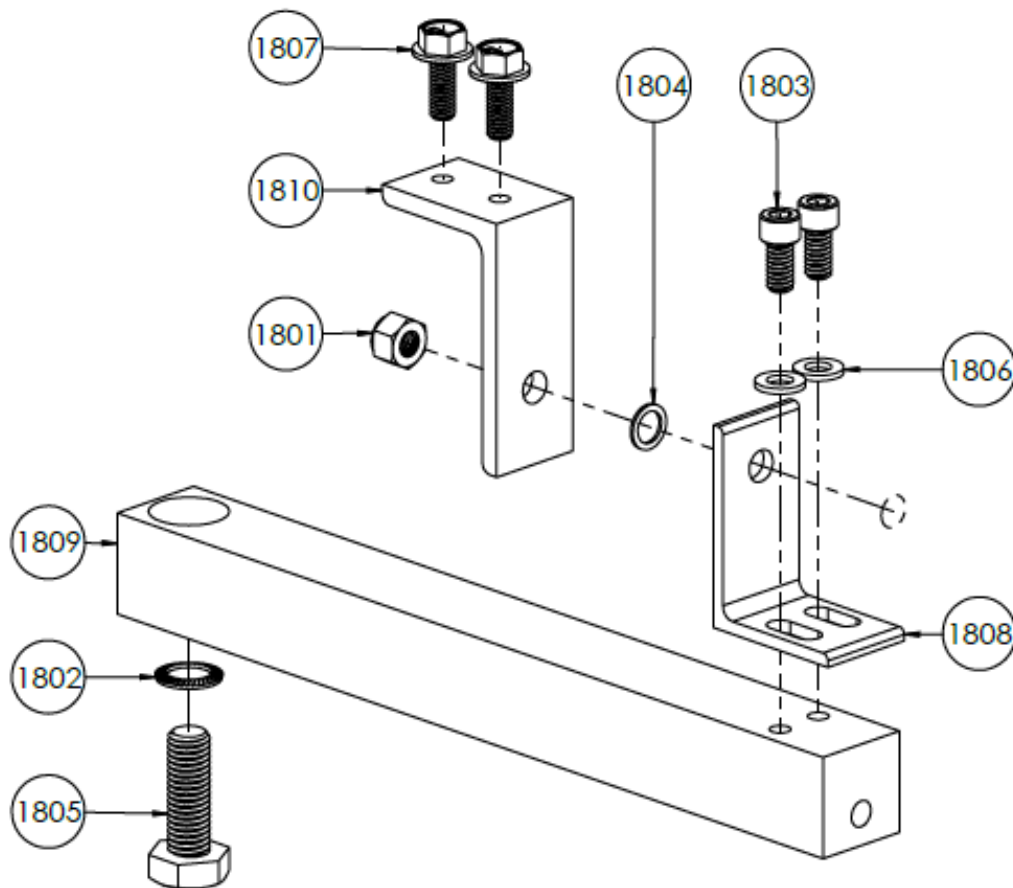

Electric Control Module - Part # 96-0345

Item No.	Part Number	Description	Qty.
1901	12-0032-25	Hex Head Cap Screw, M8-1.25 x 25mm	1
1902	12-0043-16	Serrated Flange Cap Screw, M6-1.0 x 16mm	4
1903	12-0047-25	Pan Head Phillips Screw, M5-0.8 x 25mm	4
1904	23-0032	Power Control Module	1
1905	24-0166	Wire Assembly, Fuse Block to Power Pack	1
1906	25-0032	Fuse Block, 6-Gang ATO	1
1907	25-0053	Blade Fuse, 5A	6
1908	51-1022	Heat Sink Plate	1

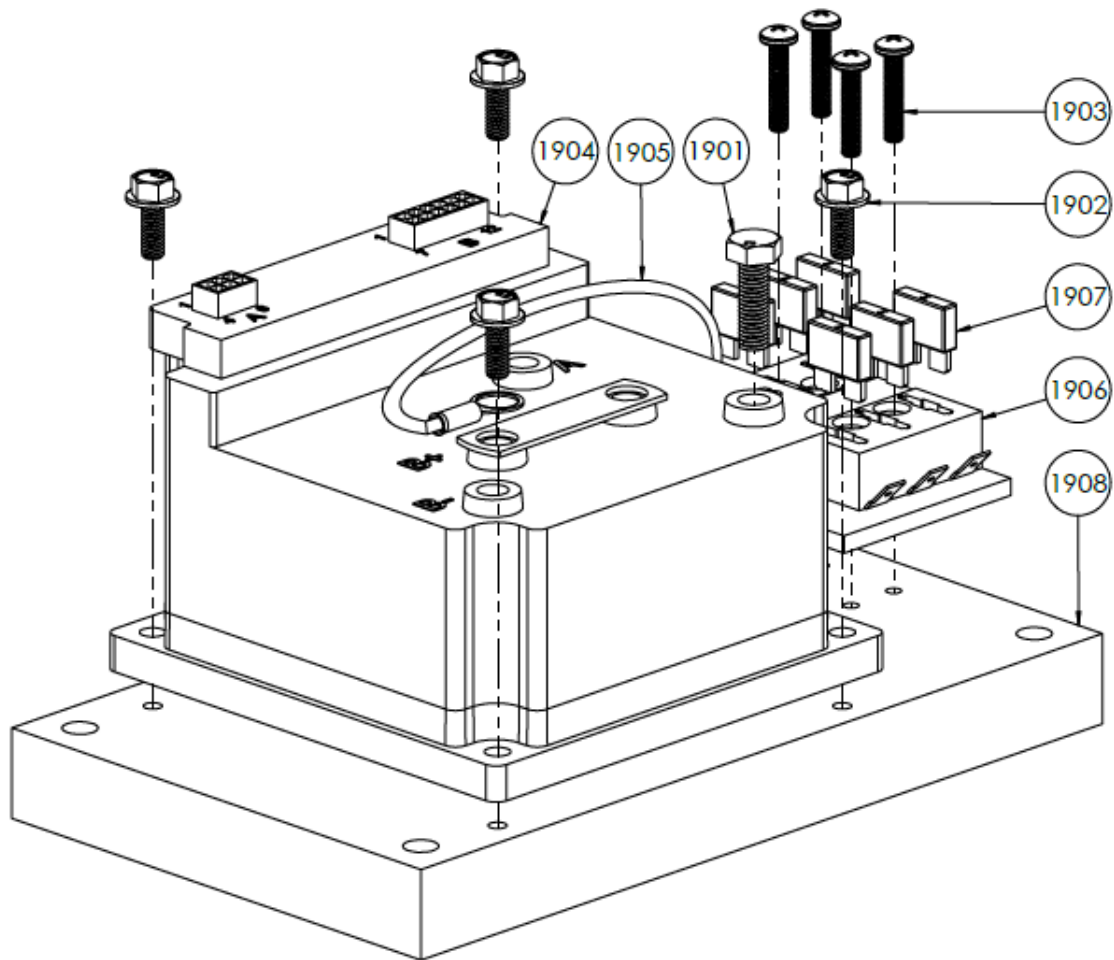

XME Battery Box - Part # 96-0339

Item No.	Part Number	Description	Qty.
2001	11-0021	Nyloc Nut, #6-32	8
2002	11-0022	Nyloc Nut, #8-32	3
2003	11-0023	Nyloc Nut, #10-24	4
2004	11-0024	Nyloc Nut, 1/4"-20	21
2005	11-0025	Nyloc Nut, 5/16"-18	1
2006	11-0030	SAE Flat Washer, #10	4
2007	11-0031	SAE Flat Washer, #8	3
2008	11-0040	Lock Washer, 5/16"	1
2009	11-0055	Hex Head Cap Screw, 1/4"-20 x 1 1/2"	4
2010	11-0102	Pan Head Phillips Screw, #8-32 x 5/8"	3
2011	11-0133	Hex Head Cap Screw, 1/4"-20 x 3/4"	15
2012	11-0140	Flat Head Socket Screw, 1/4"-20 x 3/4"	4
2013	11-0250-12	Pan Head Phillips Screw, #10-24 x 3/4"	4
2014	11-0259	SAE Flat Washer, 1/4"	22
2015	11-0315	Flat Head Phillips Screw, #6-32 x 1/2"	8
2016	12-0021-06	Nyloc Nut, M6-1.0	2
2017	12-0026-16	Hex Head Cap Screw, M6-1.0 x 16mm	2
2018	13-0005	Chrome Handle	1
2019	13-0309	Gas Spring	1
2020	13-0311	Push-in Grommet for 2" Hole	1
2021	13-0312	Loop Clamp	2
2022	22-0006	Strobe Light	1
2023	22-0073	Backup Alarm, 87 dB	1
2024	23-0009	Fuse Holder	1
2025	23-0010	Fuse, 250A	1
2026	42-0001	Fire Extinguisher	1
2027	51-0777	Slider Strip, 1/2" H x 1" W x 24" L	2
2028	51-0778	Slider Strip, 1/2" H x 2" W x 24" L	1
2029	51-0800	Slider Strip, 1/2" H x 3/4" W x 24" L	1
2030	51-0827	XME Battery Pack Hold Down Bar	1
2031	52-0177	XME Battery Box Side Access Panel	1
2032	53-0275	XME Battery Box Lid	1
2033	53-0354	XME Battery Box Weld Assembly	1

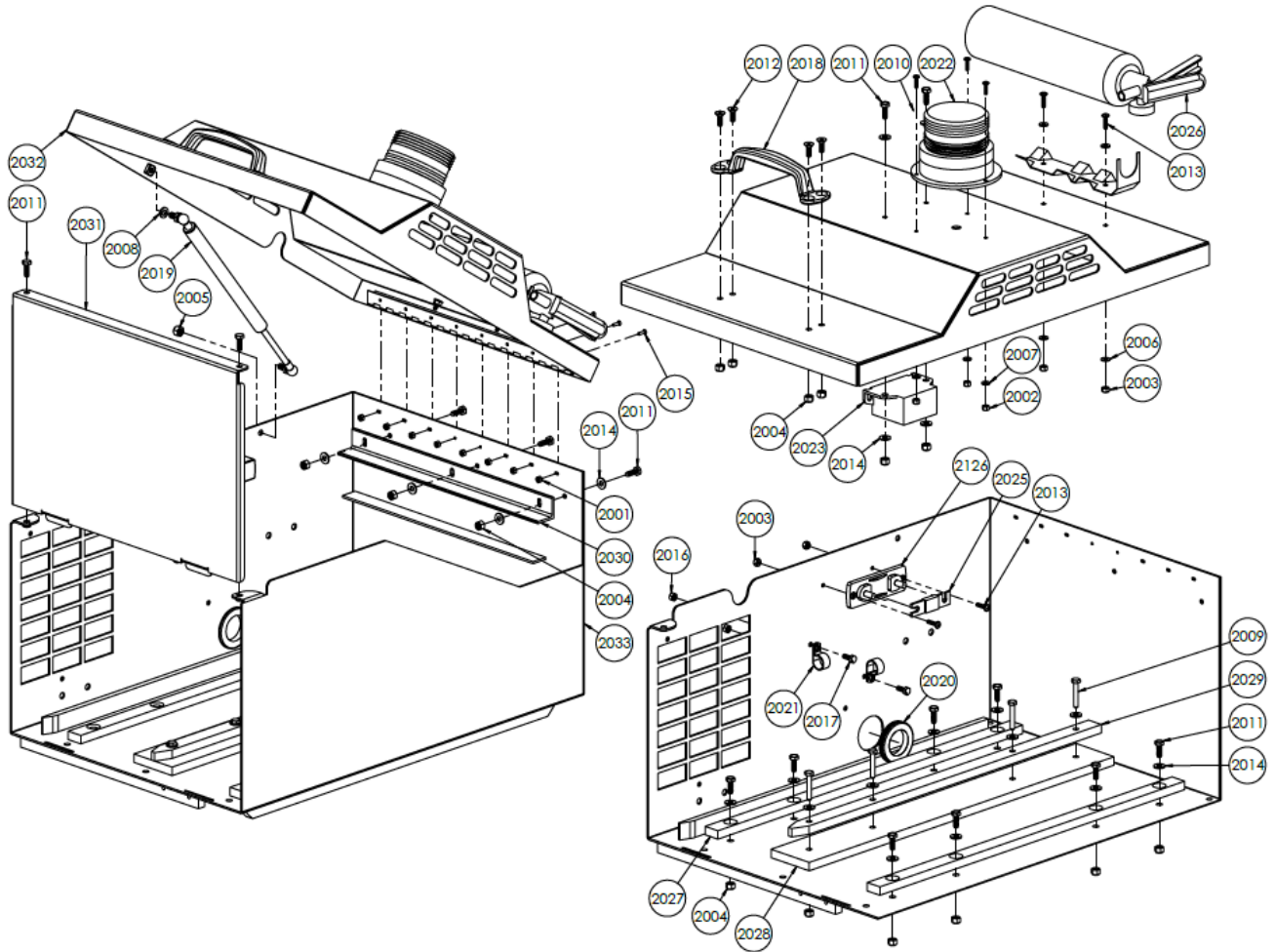

XME Front Jaw Assembly - Part # 96-0332

Item No.	Part Number	Description	Qty.
2101	11-0045	Adjustable Clevis Pin, 5/8" x 3" L	2
2102	11-0052	Hitch Pin	2
2103	12-0018-12	Lock Washer, M12	2
2104	12-0046	Flange Head Cap Screw, M12-1.75 x 90mm	2
2105	53-0375	Uni-Frame Jaw Weld Assembly	1
2106	53-0412	Uni-Frame Jaw Weight	3

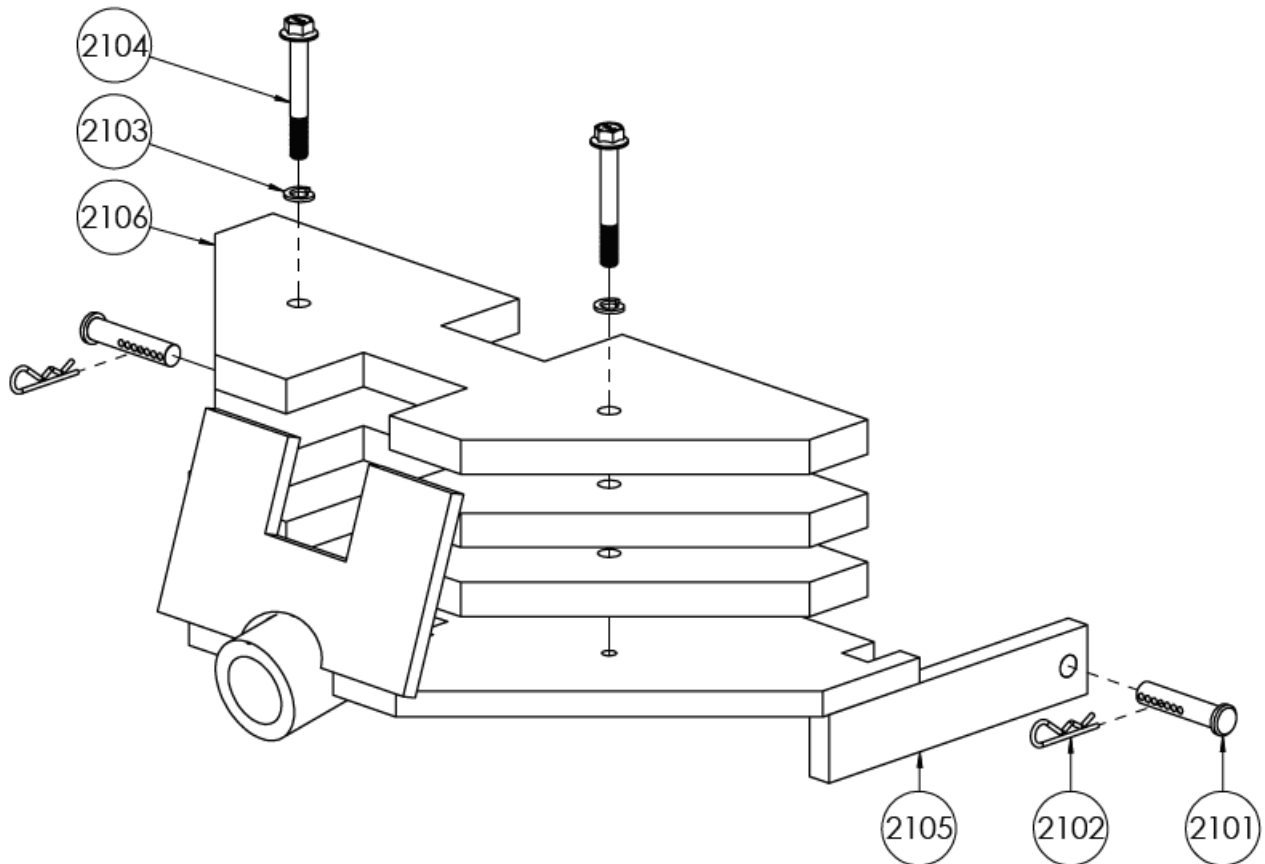

XME Battery Pack Unit - Part # 71-0016

Item No.	Part Number	Description	Qty.
2201	11-0040	Lock Washer, 5/16"	4
2202	11-0069	Lock Washer, 1/4"	2
2203	11-0150	Socket Head Cap Screw, 1/4"-20 x 1 1/2"	2
2204	11-0232	Fender Washer, 5/16"	4
2205	11-0250-08	Pan Head Phillips Screw, #10-24 x 1/2"	8
2206	11-0317	Hex Head Cap Screw, 5/16"-18 x 1/2"	4
2207	13-0307	Handle	2
2208	23-0133	Battery, 12V	2
2209	24-0161	Wire Assembly, XME Battery Pack, Positive	1
2210	24-0162	Wire Assembly, XME Battery Pack, Negative	1
2211	24-0168	Wire Assembly, XME Battery Pack, Jumper Cable	1
2212	25-0024	Blue Plug Connector	1
2213	25-0103	Battery Boot, Red	1
2214	25-0104	Battery Boot, Black	1
2215	53-0273	XME Battery Pack Case	1
2216	53-0274	XME Battery Pack Lid	1

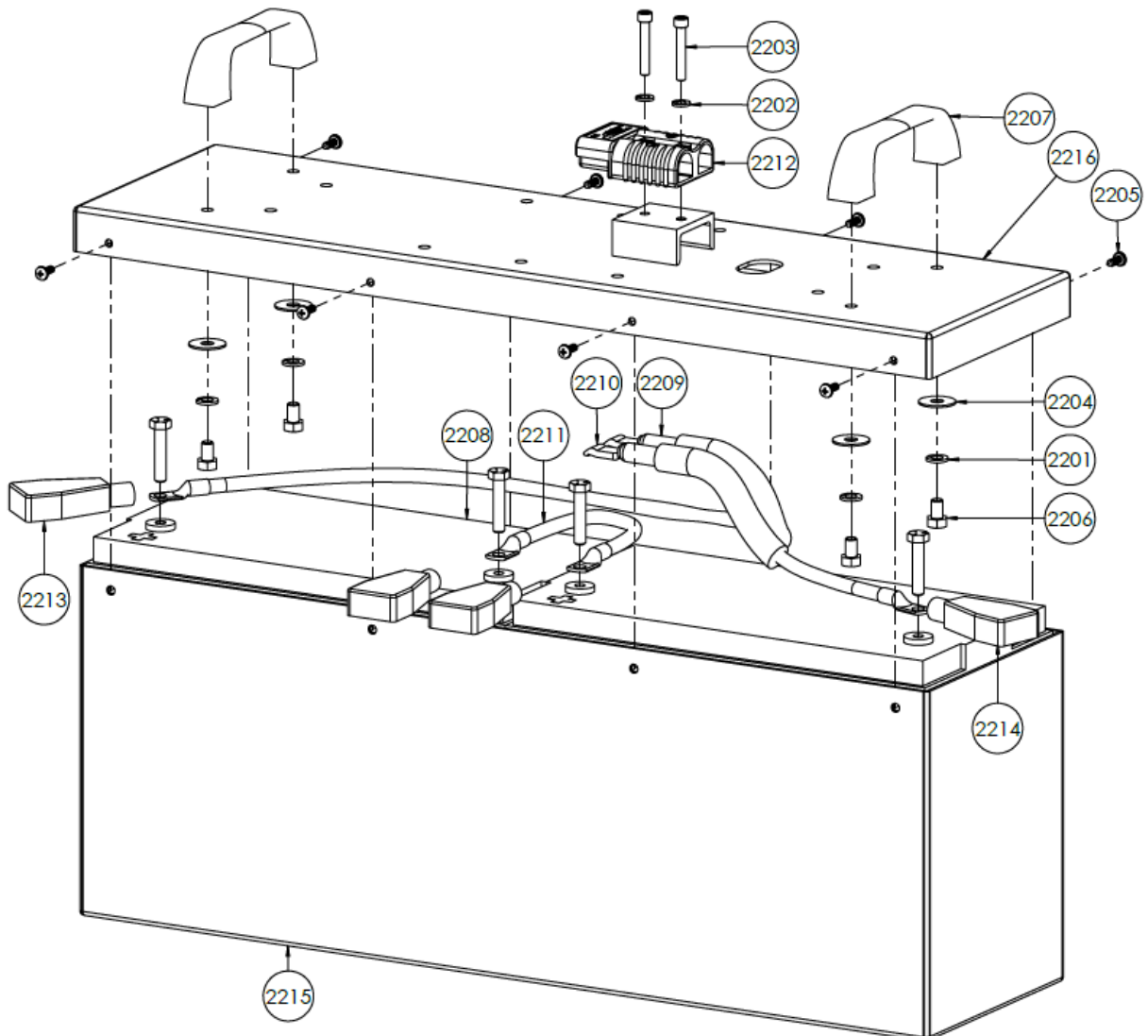

T3000XME Hydraulics

Item No.	Part Number	Description	Qty.
2301	31-0084	Hose Assembly, XME/PRO, Return to Tank	1
2302	31-0176	Hose Assembly, XME, Valve to Wheel (Universal)	4
2303	31-0214	Hose Assembly, XME, Valve to Cylinder	2
2304	31-0237	Hose Assembly, EI/XME, Tank to Pump Suction	1
2305	31-0251	Hose Assembly, XME, Filter to Tank Return	1
2306	31-0288	Hose Assembly, XME, Pump to Valve	1

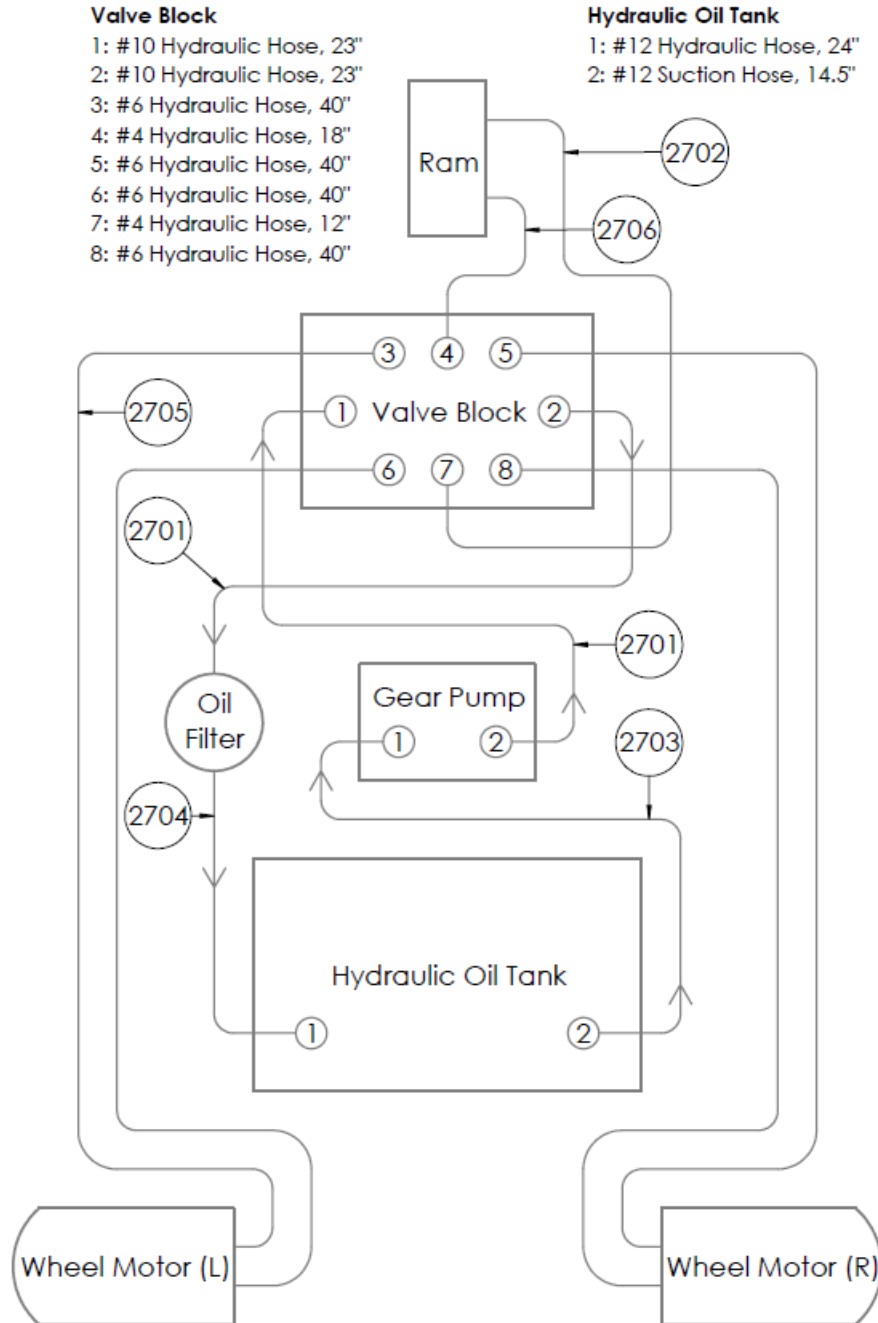

24. Warranty

Innovatech warrants to the original buyer, for a period of one (1) year or 300 operating hours (whichever comes first) from the date of delivery, that the Equipment is free from defects in materials and workmanship and that the Equipment conforms to the operating specifications supplied with the Equipment. The foregoing warranty is subject to proper operation and maintenance of the Equipment in accordance with the operating instruction and manual supplied to Buyer with the Equipment.

Warranty claims shall be made by Buyer in writing. Innovatech's sole obligation under the foregoing warranty, where it appears to Innovatech's satisfaction that the defect was present at the time of delivery, is at Innovatech's sole option, to repair, replace or correct any such defect.

EXCEPT AS STATED ABOVE THERE ARE NO WARRANTIES, EXPRESS OR IMPLIED. INNOVATECH EXPRESSLY DISCLAIMS ANY WARRANTY, EXPRESS OR IMPLIED, THAT EQUIPMENT SOLD HEREUNDER IS OF MERCHANTABLE QUALITY OR THAT IT CAN BE USED FOR OR IS FIT FOR ANY PARTICULAR PURPOSE. ANY DESCRIPTION OF THE EQUIPMENT IN THIS AGREEMENT OR IN MANUALS, BROCHURES OR LITERATURE AND ANY USE OF ANY SAMPLE, MODEL OR PROTOTYPE OF THE EQUIPMENT IS FOR THE SOLE PURPOSE OF IDENTIFYING OR ILLUSTRATING THE EQUIPMENT, IS NOT PART OF THE BASIS OF THE AGREEMENT BETWEEN INNOVATECH AND BUYER, AND DOES NOT CONSTITUTE A WARRANTY THAT THE EQUIPMENT, AS SUPPLIED, WILL CONFORM TO ANY DESCRIPTION OR TO ANY SAMPLE, MODEL OR PROTOTYPE. INNOVATECH DISCLAIMS ANY WARRANTY RESPECTING OPERATING CAPACITY OR CAPABILITY OF THE EQUIPMENT OR THE ABILITY OF THE EQUIPMENT TO MEET ANY PARTICULAR NEEDS OF THE BUYER. THE EQUIPMENT IS POWERED TO OPERATE AS STATED IN THE OPERATING SPECIFICATIONS SUPPLIED WITH THE EQUIPMENT BUT IT IS UNDERSTOOD AND AGREED TO BUY BUYER THAT ACTUAL OPERATING CAPABILITIES VARY UNDER DIFFERENT OPERATING CONDITIONS FOR WHICH INNOVATECH CAN ASSUME NO RESPONSIBILITY.

BUYER'S EXCLUSIVE REMEDY FOR CLAIMS ARISING UNDER THIS AGREEMENT SHALL BE FOR REPAIR OR, AT INNOVATECH'S SOLE OPTION, REPLACEMENT OF ANY ITEM OF DEFECTIVE EQUIPMENT. INNOVATECH'S LIABILITY FOR ANY LOSSES OR DAMAGE, WHETHER ON ACCOUNT OF NEGLIGENCE, BREACH, AND WARRANTY OR OTHERWISE SHALL IN NO EVENT EXCEED THE PURCHASE PRICE OF THE PARTICULAR ITEM OF EQUIPMENT WITH RESPECT TO WHICH SUCH LOSSES OR DAMAGE OCCURRED.

IN NO EVENT WILL INNOVATECH BE LIABLE FOR ANY DAMAGES CAUSED BY BUYER'S FAILURE TO PERFORM BUYER'S RESPONSIBILITIES, OR FOR ANY LOST PROFITS, LOST PRODUCTION, LOSS OF ANTICIPATED PROFITS OF OTHER INCIDENTAL OR CONSEQUENTIAL DAMAGES, EVEN IF INNOVATECH HAS BEEN ADVISED OF THE POSSIBILITY OF SUCH DAMAGES.

IN NO EVENT WILL INNOVATECH BE LIABLE FOR ANY DAMAGES RESULTING FROM ANY CLAIM AGAINST BUYER BY ANY OTHER PARTY.

FACTORY SERVICE

A warranty will not be valid unless a written claim authorization comes with returned parts. Innovatech will not provide for any shipping costs for items returned for repair. To obtain warranty repairs, buyer must prepay shipment and return all warranty parts to Innovatech. Damage occurring during shipment is deemed the responsibility of the carrier and claims should be made directly with such carrier.

It will be the customer's responsibility to pay for any non-warranty replacement parts plus the current hourly labor rates for any work done on any machine or part. Service is available upon request; call Innovatech for current labor rates.

Innovatech™

BARTELL GLOBAL



Bartell Morrison Inc.
 375 Annagem Boulevard
 Mississauga, Ontario, Canada
 L5T 3A7
 Tel: 1-647-953-4100
 Fax: 1-647-953-4101



Bartell Morrison (USA) LLC
 200 Commerce Drive, Unit A
 Freehold, New Jersey, USA
 07728
 Tel: 1-848-225-8100
 Fax: 1-848-225-8101



Innovatech
 4701 Allmond Ave
 Louisville, Kentucky, USA
 40209
 Tel: 1-425-405-9100
 Fax: 1-425-405-9101



SPE International
 Honeyholes Lane
 Dunholme, Lincoln, UK
 LN2 3SU
 Tel: +44 (0)1673 860709
 Fax: +44 (0)1673 861119

www.BARTELLGLOBAL.com